

**1970**

**TRIUMPH**

**REPLACEMENT  
PARTS CATALOGUE**

**UNIT CONSTRUCTION 40 cu. ins. TWINS**

TR6R TIGER 650

TR6C TROPHY 650

T120R BONNEVILLE 120

**TRIUMPH ENGINEERING COMPANY LIMITED  
MERIDEN WORKS · ALLESLEY · COVENTRY · ENGLAND  
TELEPHONE MERIDEN 331    TELEX 31305    TELEGRAMS "TRUSTY COVENTRY"**

# INDEX

	Page		Page
AIR FILTER ... ..	59	HANDLEBARS ... ..	65
ALTERNATOR ... ..	13, 35	HANDLEBAR MOUNTINGS ... ..	49
AUTO-ADVANCE UNIT ... ..	25	HEADLAMP ... ..	77, 81
		HEAT SINK ... ..	79
		HORN ... ..	79
BATTERY CARRIER ... ..	59		
BRAKE SWITCHES ... ..	67	KICKSTARTER ... ..	31
BREATHER PIPES ... ..	57		
		MANIFOLD ... ..	19
CAMSHAFT, INLET AND EXHAUST	13	MUFFLERS ... ..	43, 45
CAPACITOR, IGNITION ... ..	77		
CARBURETOR ... ..	71, 73	OIL PUMP ... ..	19
CARTON PACKS ... ..	9	OIL TANK ... ..	57
CENTRE STAND ... ..	37	OIL PIPES ... ..	57
CHAINS ... ..	35		
CHAINCASE ... ..	35	PISTONS ... ..	13
CLUTCH ... ..	33	PROP STAND ... ..	37
CLUTCH LEVER ASSEMBLY ... ..	31	PUSH RODS ... ..	21, 23
COIL ... ..	79		
CONDENSER PACK ... ..	79	REAR WHEEL ... ..	53
CONNECTING RODS ... ..	13	RECTIFIER ... ..	79
CONTACT BREAKER ... ..	25	REFLECTORS ... ..	55
CONTROL CABLES ... ..	67	ROCKERS ... ..	23
CONTROL LEVERS ... ..	65		
CRANKCASE ... ..	15	SIDE PANEL ... ..	61
CRANKCASE UNDERSHIELD ... ..	41	SPARKING PLUG ... ..	79
CRANKSHAFT ... ..	13	SPEEDOMETER ... ..	75
CYLINDERS ... ..	21, 23	SPEEDOMETER GEARBOX ... ..	75
CYLINDER HEAD ... ..	21, 23	STEERING DAMPER ... ..	49
		STEERING RACES ... ..	37
ENGINE PLATES ... ..	41	SUSPENSION UNITS ... ..	39
ENGINE TORQUE STAY ... ..	41	SWINGING FORK ... ..	39
EXHAUST PIPES ... ..	43, 45	SWITCHES ... ..	81
EXHAUST PIPE ADAPTOR ... ..	21, 23		
		TACHOMETER ... ..	75
FENDERS ... ..	63	TACHOMETER GEARBOX ... ..	75
FOOTRESTS ... ..	41, 69	TAIL LAMP ... ..	81
FRAME ... ..	37	TAPPETS ... ..	19
FRONT BRAKE ... ..	51	TIMING GEARS ... ..	13
FRONT FORKS ... ..	47	TOOLKIT ... ..	69
FRONT WHEEL ... ..	51	TWIN SEAT ... ..	61
FUSE ASSEMBLY ... ..	59		
		VALVES ... ..	21, 23
GAS TANK ... ..	55	VALVE GUIDES ... ..	21, 23
GASKET SET ... ..	9		
GEARBOX ... ..	27, 29, 31	WIRING HARNESS ... ..	81
		ZENER DIODE ... ..	79

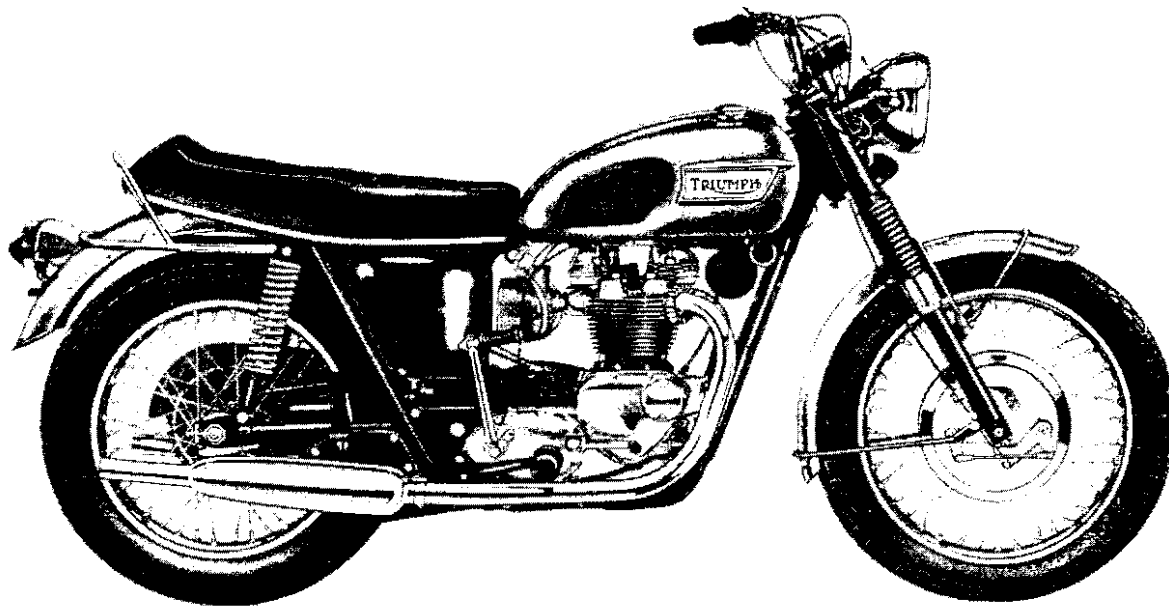

### TIGER 650 (TR6R) TECHNICAL DATA

Bore and stroke...	...	...	...	...	...	...	...	...	71 x 82 mm. 2.79 x 3.23 ins.
Capacity ...	...	...	...	...	...	...	...	...	649 c.c. (40 cu. ins.)
Compression ratio	...	...	...	...	...	...	...	...	9 : 1
Spark plugs	...	...	...	...	...	...	...	...	Champion N3
Carburetor	...	...	...	...	...	...	...	...	Amal Concentric 930
			Main jet	...	...	...	...	...	230
			Needle jet	...	...	...	...	...	-106
			Throttle valve	...	...	...	...	...	No. 3½
Gearbox sprocket	...	...	...	...	...	...	...	...	19 teeth
Chains	...	...	Front	...	...	...	...	...	¾" Duplex x 84 links
			Rear	...	...	...	...	...	½" x ¾" x 104 links
Capacities	...	...	Gas Tank	...	...	...	...	...	3½ U.S. galls. (16 litres)
			Oil Tank	...	...	...	...	...	6.25 U.S. pints (3.125 litres)
			Gearbox	...	...	...	...	...	¾ pint (500 c.c.)
			Primary Chaincase	...	...	...	...	...	⅝ pint (350 c.c.)
			Front Forks (each leg)	...	...	...	...	...	½ pint (200 c.c.)
Brakes	...	...	Front, diameter...	...	...	...	...	...	8" (20.32 cm.)
			Rear, diameter	...	...	...	...	...	7" (17.78 cm.)
Tire size	...	...	Front	...	...	...	...	...	3.25 x 19
			Rear	...	...	...	...	...	4.00 x 18

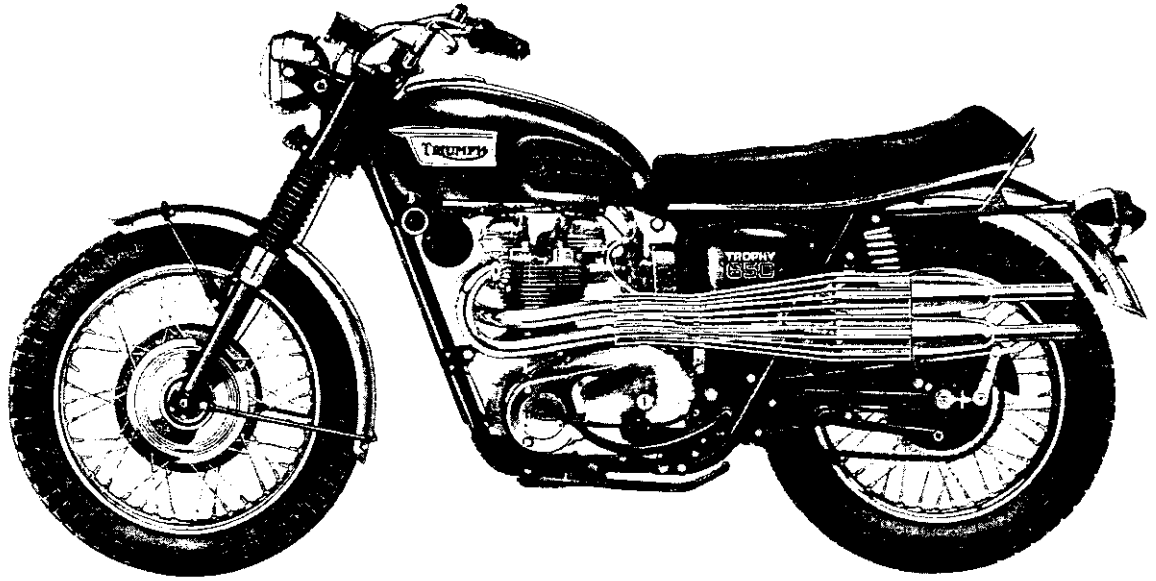

### TROPHY 650 (TR6C) TECHNICAL DATA

<b>Bore and stroke...</b>	...	...	...	...	...	...	...	...	71 x 82 mm. 2.79 x 3.23 ins.
<b>Capacity</b>	...	...	...	...	...	...	...	...	649 c.c. (40 cu. ins.)
<b>Compression ratio</b>	...	...	...	...	...	...	...	...	9 : 1
<b>Spark plugs</b>	...	...	...	...	...	...	...	...	Champion N3
<b>Carburetor</b>	...	...	...	...	...	...	...	...	Amal Concentric 930
									Main jet ... .. 230
									Needle jet ... .. -106
									Throttle valve ... .. No. 3½
<b>Gearbox sprocket</b>	...	...	...	...	...	...	...	...	18 teeth
<b>Chains</b>	...	...	...	...	...	...	...	...	Front ... .. ¾" Duplex x 84 links
									Rear ... .. 5/8" x 3/8" x 104 links
<b>Capacities</b>	...	...	...	...	...	...	...	...	Gas Tank ... .. 2½ U.S. galls. (11 litres)
									Oil Tank ... .. 6.25 U.S. pints (3.125 litres)
									Gearbox ... .. 7/8 pint (500 c.c.)
									Primary Chaincase ... .. 5/8 pint (350 c.c.)
									Front Forks (each leg) ... .. ½ pint (200 c.c.)
<b>Brakes</b>	...	...	...	...	...	...	...	...	Front, diameter... .. 8" (20.32 cm.)
									Rear, diameter ... .. 7" (17.78 cm.)
<b>Tire size</b>	...	...	...	...	...	...	...	...	Front ... .. 3.50 x 19
									Rear ... .. 4.00 x 18

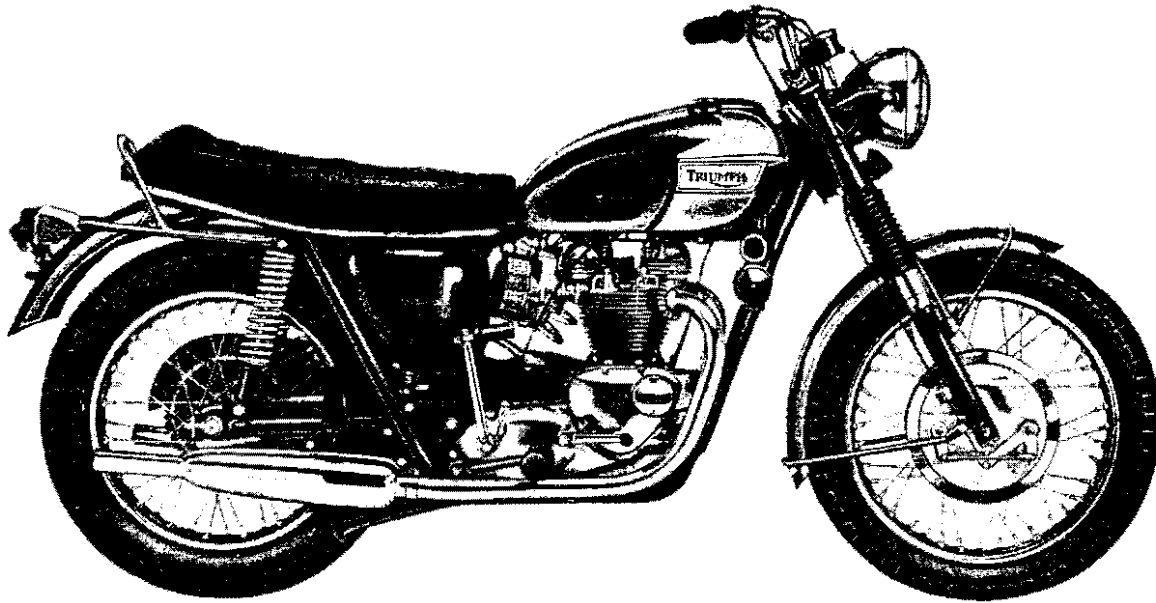

### BONNEVILLE (T120R) TECHNICAL DATA

Bore and stroke...	...	...	...	...	...	...	...	...	71 x 82 mm. 2.79 x 3.23 ins.
Capacity	...	...	...	...	...	...	...	...	649 c.c. (40 cu. ins.)
Compression ratio	...	...	...	...	...	...	...	...	9 : 1
Spark plugs	...	...	...	...	...	...	...	...	Champion N3
Carburetors	...	...	...	...	...	...	...	...	2 Amal Concentric 930
								Main jet	190
								Needle jet	.106
								Throttle valve	No. 3
Gearbox sprocket	...	...	...	...	...	...	...	...	19 teeth
Chains	...	...	...	...	...	...	...	Front	$\frac{3}{8}$ " Duplex x 84 links
								Rear	$\frac{5}{8}$ " x $\frac{3}{8}$ " x 104 links
Capacities	...	...	...	...	...	...	...	Gas Tank	2 $\frac{3}{4}$ U.S. galls. (11 litres)
								Oil Tank	6.25 U.S. pints (3.125 litres)
								Gearbox	$\frac{7}{8}$ pint (500 c.c.)
								Primary Chaincase	$\frac{5}{8}$ pint (350 c.c.)
								Front Forks (each leg)	$\frac{1}{2}$ pint (200 c.c.)
Brakes	...	...	...	...	...	...	...	Front, diameter...	8" (20.32 cm.)
								Rear, diameter	7" (17.78 cm.)
Tire Size	...	...	...	...	...	...	...	Front	3.25 x 19
								Rear	4.00 x 18

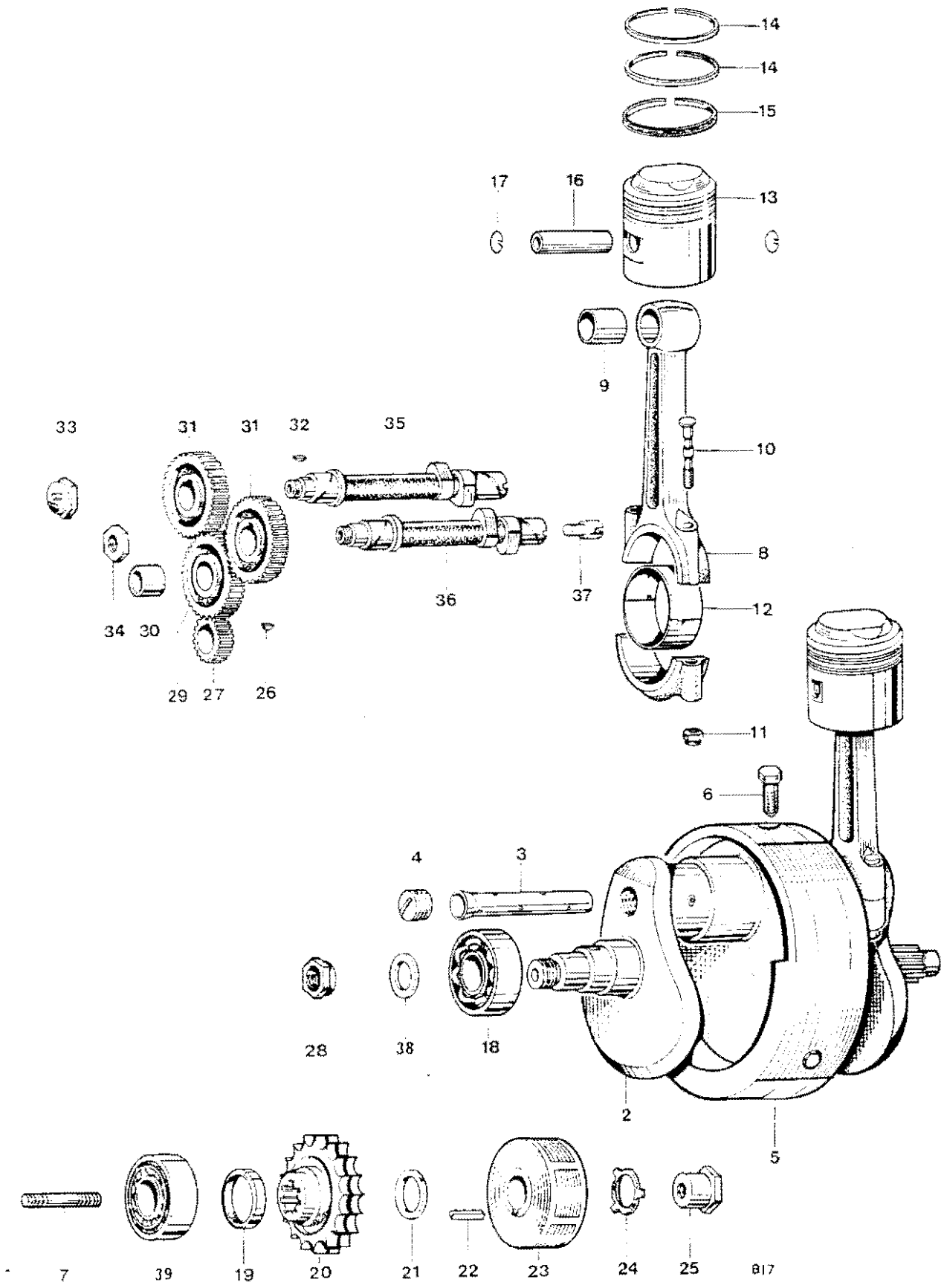

Fig. 1. CRANKSHAFT AND CONNECTING RODS

**CRANKSHAFT AND CONNECTING RODS**

1	E9686	CRANKSHAFT AND FLYWHEEL ASSEMBLY	1	
2	E4643	CRANKSHAFT C/W. OIL TUBE	1	
3	E3903	Oil tube	1	
4	E3905	Screwed plug	1	
5	E9687	Flywheel	1	
6	*E3907	Flywheel bolt	3	
7	E3114	Crankshaft stud (1 $\frac{3}{8}$ in. O.A.)	1	
8	E9525	CONNECTING ROD	2	
9	E1511	Small end bush	2	
10	E6576	Connecting rod bolt	4	
11	S2016	Self locking nut	4	
12	E3586	Big end bearing (Available in —010 in. and —020 in. undersizes)	4	
13	E9488	PISTON COMPLETE 9 : 1 C.R.	2	
13	E6867	PISTON COMPLETE 11 : 1 C.R.	2	
14	E6864	Taper compression ring	4	
15	E6865	Oil control ring	2	
16	E6861	Gudgeon pin (short)	2	
17	E6869	Circlip	4	
18	E1591	Main bearing, right	1	
19	E3876	Oil seal	1	
20	E5450	Engine sprocket, 29 teeth Duplex	1	
21	E4912	Distance piece	1	
22	E10082	Rotor key	1	
23	54213901	Rotor (99-0739)	1	
24	E3975	Tab washer	1	
25	E3977	Nut	1	
26	E1580	Key	1	
27	E4564	Timing pinion	1	
28	E4565	Nut	1	
29	E6159	INTERMEDIATE WHEEL	1	
30	E400	Intermediate wheel bush	1	
31	E4562	Camshaft wheel	2	
32	E1558	Camshaft key	2	
33	E11007	Inlet camshaft nut	1	
34	E6523	Exhaust camshaft nut	1	
35	E11063	Inlet camshaft, Racing type	1	
36	E9989	EXHAUST CAMSHAFT, RACING TYPE	1	
37	E9988	Tachometer drive plug	1	
38	E3300	Clamping washer	1	
39	E2879	Main bearing, left	1	

\* Use D524 Loctite Sealant

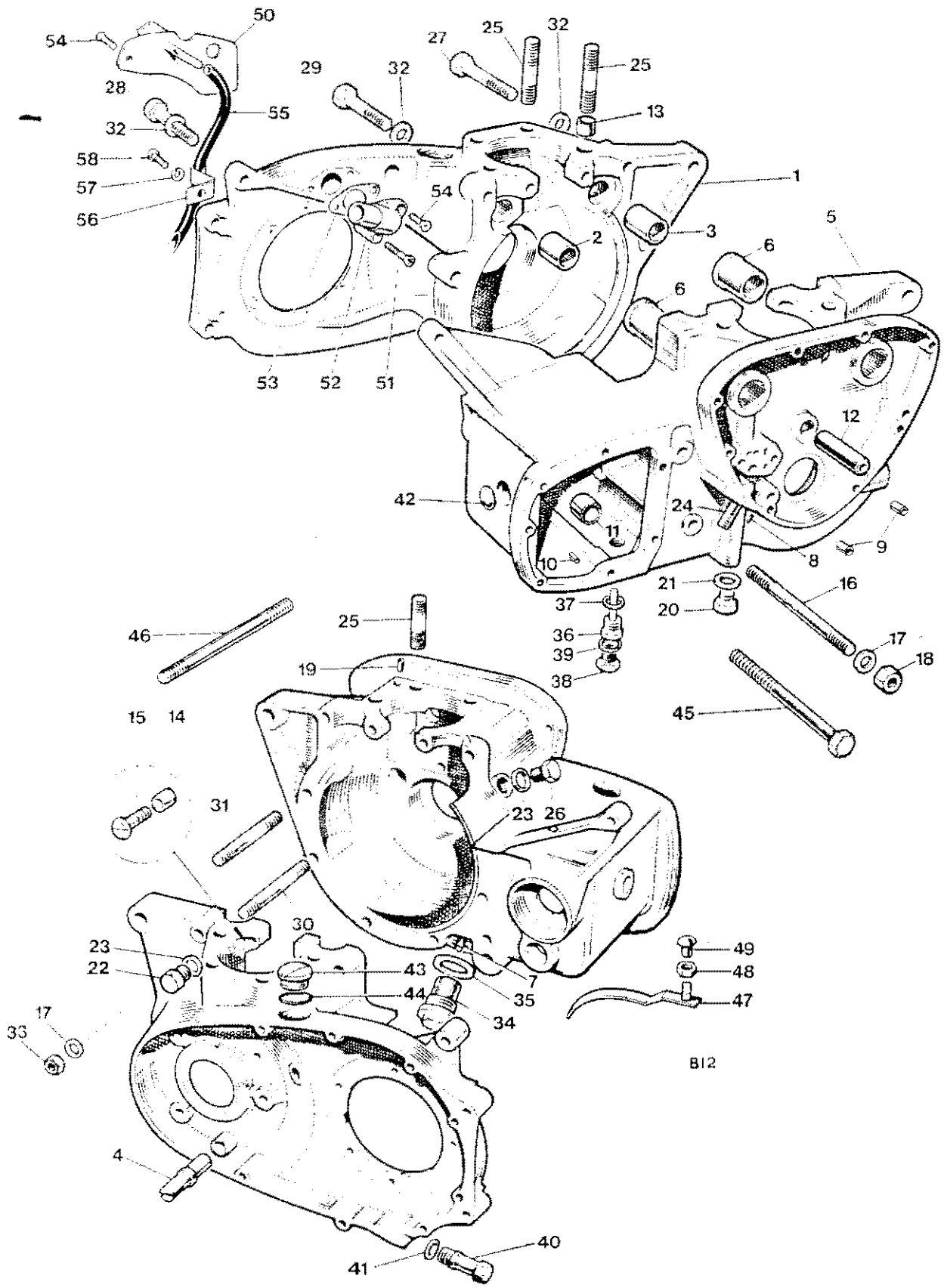

Fig. 2. CRANKCASE



Ref. No.	Part No.	DESCRIPTION	QUANTITY	REMARKS
<b>CRANKCASE</b>				
1	E11266	CRANKCASE DRIVE SIDE ... ..	1	
2	E10287	Camshaft bush ... ..	1	
3	E10287	Camshaft bush ... ..	1	
4	E5976	Chain tensioner abutment ... ..	1	
5	E11267	CRANKCASE TIMING SIDE ... ..	1	
6	E10286	Camshaft bush ... ..	2	
7	E4538	Scavenge pipe ... ..		Reference only
8	E6386	Locating peg (at oil pipes) ... ..		Reference only
9	T989	Hollow dowel ... ..	2	
10	T912	Locating peg (L/S at thrust washer) ... ..	1	
11	T1606	Needle roller bearing, layshaft ... ..	1	
12	E375	Intermediate wheel spindle ... ..	1	
13	E8751	Hollow dowel ... ..	1	
14	E3716	Hollow dowel ... ..	1	
15	S1873	Screw ( $1\frac{1}{8}$ in. U.H.) ... ..	2	
16	14-1445	Stud ( $4\frac{1}{2}$ in. O.A.) ... ..	1	
17	S25-2	Plain washer ... ..	2	
18	14-0303	Nut ... ..	2	
19	E1532	Hollow dowel, tappet oil feed ... ..	2	
20	E9330	Oilway plug ... ..	1	
21	F1880	Copper washer ... ..	1	
22	S1871	Tachometer drive plug (L.H. thread) ... ..	1	
23	E8896	Fibre washer ... ..	2	
24	S1863	Oil pipe stud ( $1\frac{1}{2}$ in. O.A.) ... ..	1	
25	S1865	Cylinder stud ( $1\frac{3}{8}$ in. O.A.) ... ..	8	
26	S1872	Plug, timing hole ... ..	1	
27	S1870	Bolt ( $2\frac{1}{2}$ in. U.H.) UN ... ..	1	
28	14-6220	Bolt ( $1\frac{3}{8}$ in. U.H.) UN ... ..	1	
29	S1869	Bolt ( $1\frac{1}{8}$ in. U.H.) UN ... ..	1	
30	E4856	Stud ( $5\frac{1}{8}$ in. O.A.) ... ..	1	
31	E2888	Stud ( $3\frac{5}{8}$ in. O.A.) ... ..	2	(TR6C 3 off)
32	S25-3	Plain washer ... ..	11	
33	S1-51	Nut ... ..	8	
34	E9336	Crankcase filter UN ... ..	1	
35	E5315	Joint washer ... ..	1	
36	T3668	Drain plug (with level tube) UN ... ..	1	
37	T1257	Fibre washer ... ..	1	
38	S543	Level plug UN ... ..	1	
39	E2441	Copper washer ... ..	1	
40	E6347	Drain and adjuster plug ... ..	1	
41	T1738	Fibre washer ... ..	1	
42	T1920	Blanking plug ... ..	1	
43	T2166	Filler plug UN ... ..	2	
44	E8782	"O" ring ... ..	2	
45	14-6242	Bolt (4 in. U.H.) UN ... ..	1	
46	E5963	Stud ( $4\frac{3}{8}$ in. O.A.) ... ..	1	(Except TR6C)
47	E8892	Protection blade ... ..	1	
48	14-1301	Self locknut UN ... ..	1	
49	E7573	Rubber plug (for protection blade stud hole) ... ..	1	TR6R, T120R

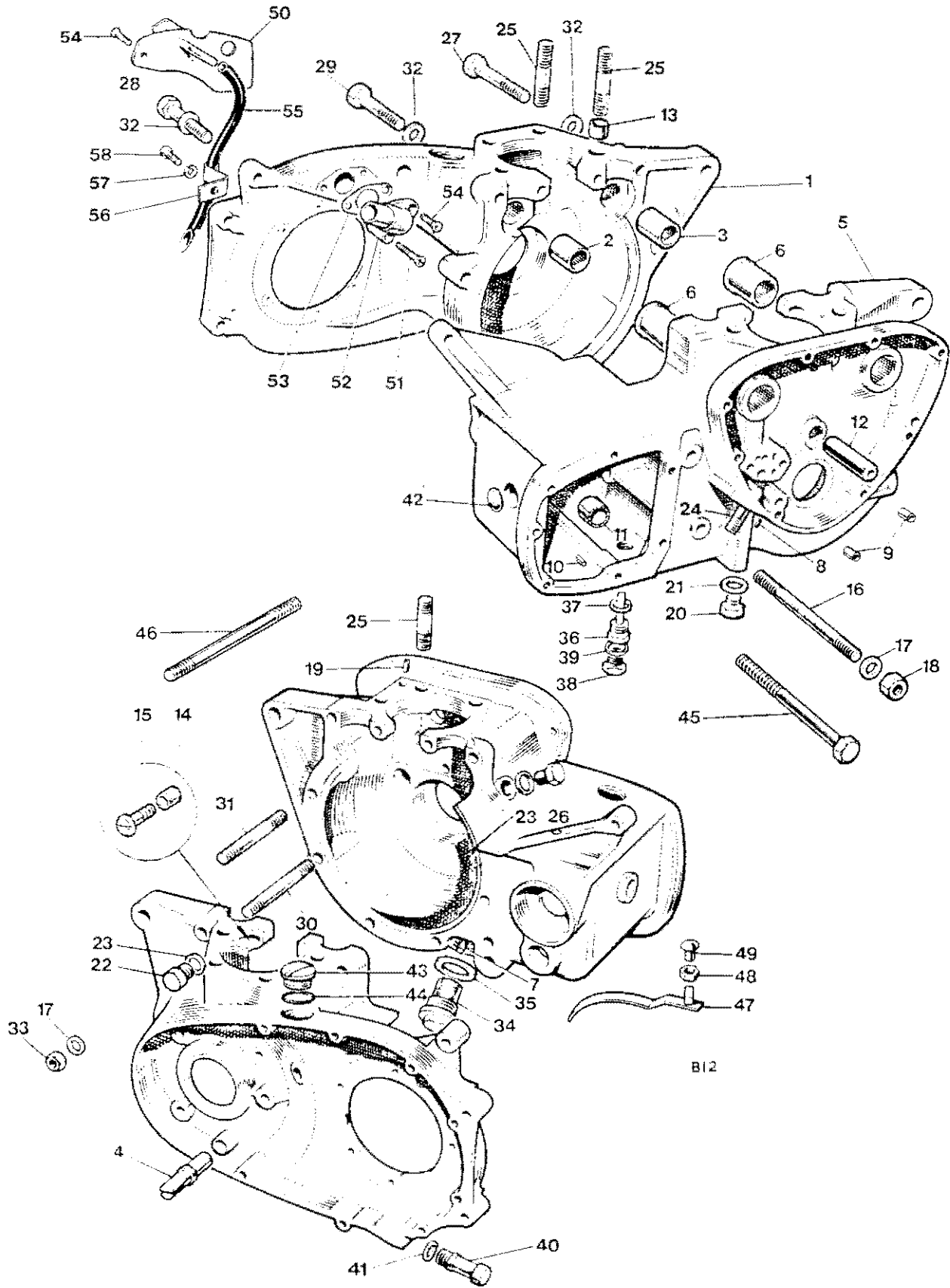

Fig. 2. CRANKCASE

Ref. No.	Part No.	DESCRIPTION	QUANTITY	REMARKS
----------	----------	-------------	----------	---------

**CRANKCASE (continued)**

50	E11072	Breather cover plate assembly	1	
51	E11075	Screw	1	
52	E9335	Outlet stub	1	
53	E11076	Joint washer	1	
54	E11077	Screw	2	
55	E11078	Tube, primary chain oiler	1	
56	E4705	Clip	1	
57	S26-2	Spring washer	1	
58	14-0101	Bolt ( $\frac{7}{16}$ in. U.H.)	1	

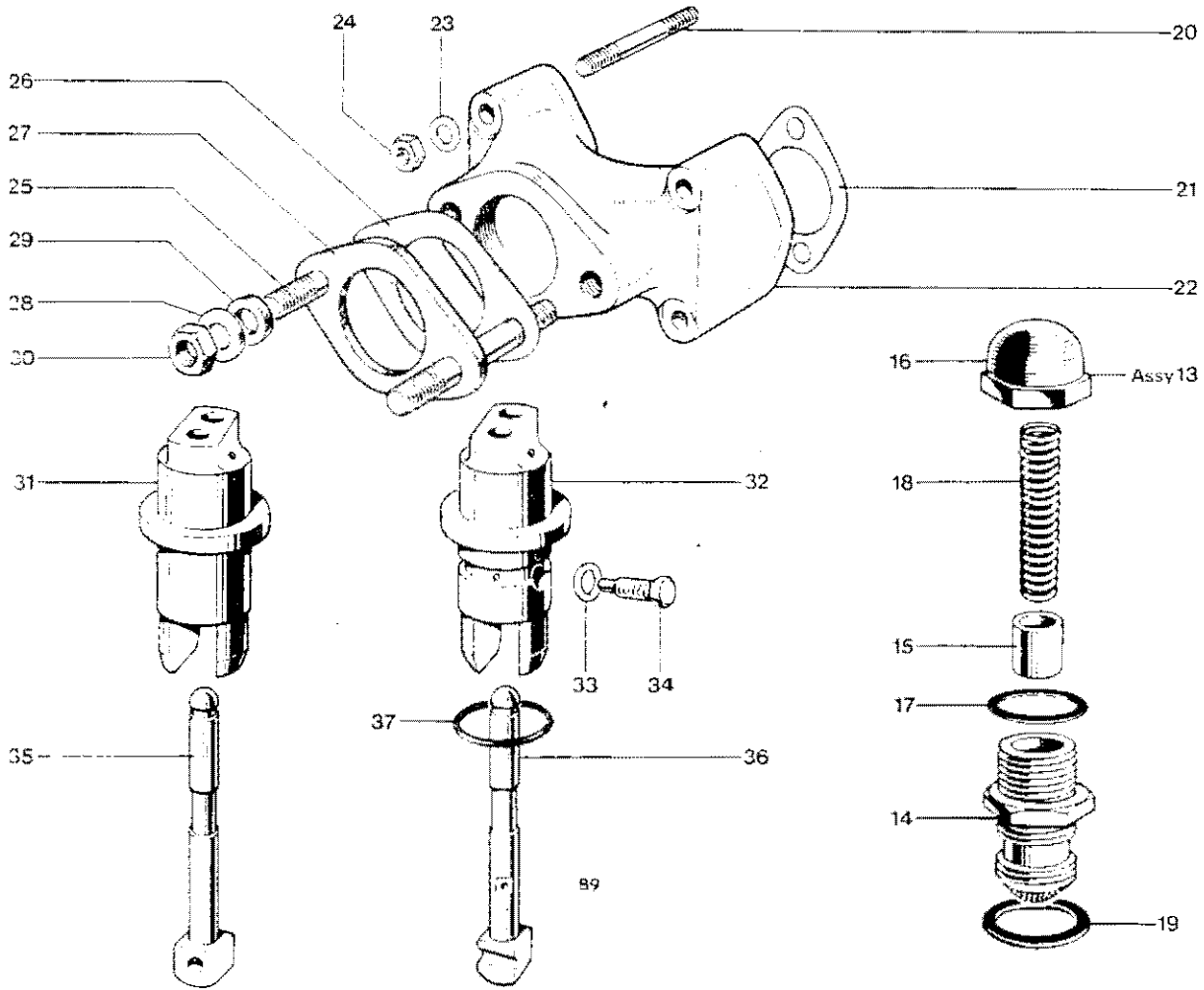
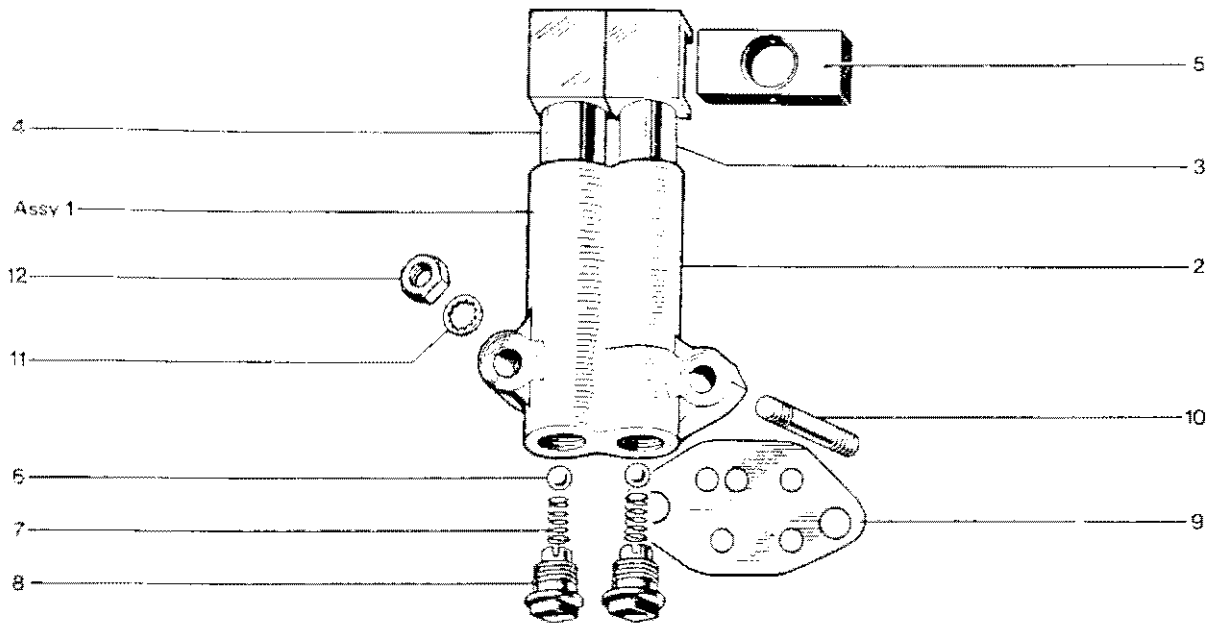

Fig. 3. OIL PUMP, RELEASE VALVE, MANIFOLD AND TAPPETS

**OIL PUMP, RELEASE VALVE, MANIFOLD AND TAPPETS**

1	E9421	OIL PUMP	1	
2	Reference only	Pump body...	1	
3	E9269	Feed plunger	1	
4	E6681	Scavenge plunger	1	
5	E495	Drive block	1	
6	S70-7	Valve ball ( $\frac{7}{32}$ in. dia.)	2	
7	E403	Valve spring	2	
8	E2360	Screwed plug	2	
9	E3730	Joint washer	1	
10	S1864	Oil pump stud ( $1\frac{5}{16}$ in. U.H.)	2	
11	E3887	Serrated washer	2	
12	S1906	Nut	2	
13	E6595	OIL RELEASE VALVE	1	
14	E7590	Valve body	1	
15	GS251	Piston	1	
16	E6596	Cap	1	
17	GS254	Fibre washer	1	
18	E7591	Main spring	1	
19	E1670	Fibre washer	1	
20	S1876	Stud ( $1\frac{1}{8}$ in. O.A.)	4	
21	E5660	Joint washer	2	} TR6R & TR6C
22	E9973	Inlet manifold	1	
23	S25-13	Plain washer	4	
24	S1877	Nut	4	
25	S1996	Stud ( $1\frac{7}{32}$ in. O.A.)	2	
26	E4919	Joint washer	1	
27	E4918	Insulating block	1	
28	E9555	Cup	2	
29	E9554	"O" ring	2	
30	14-1301	Nut	2	
31	E9352	Inlet tappet guide	1	
32	E9353	Exhaust tappet guide	1	
33	E2441	Copper washer	2	
34	H200	Set bolt	2	
35	E3059R	Inlet tappet	2	
36	E8801	Exhaust tappet	2	
37	E7563	"O" ring	2	

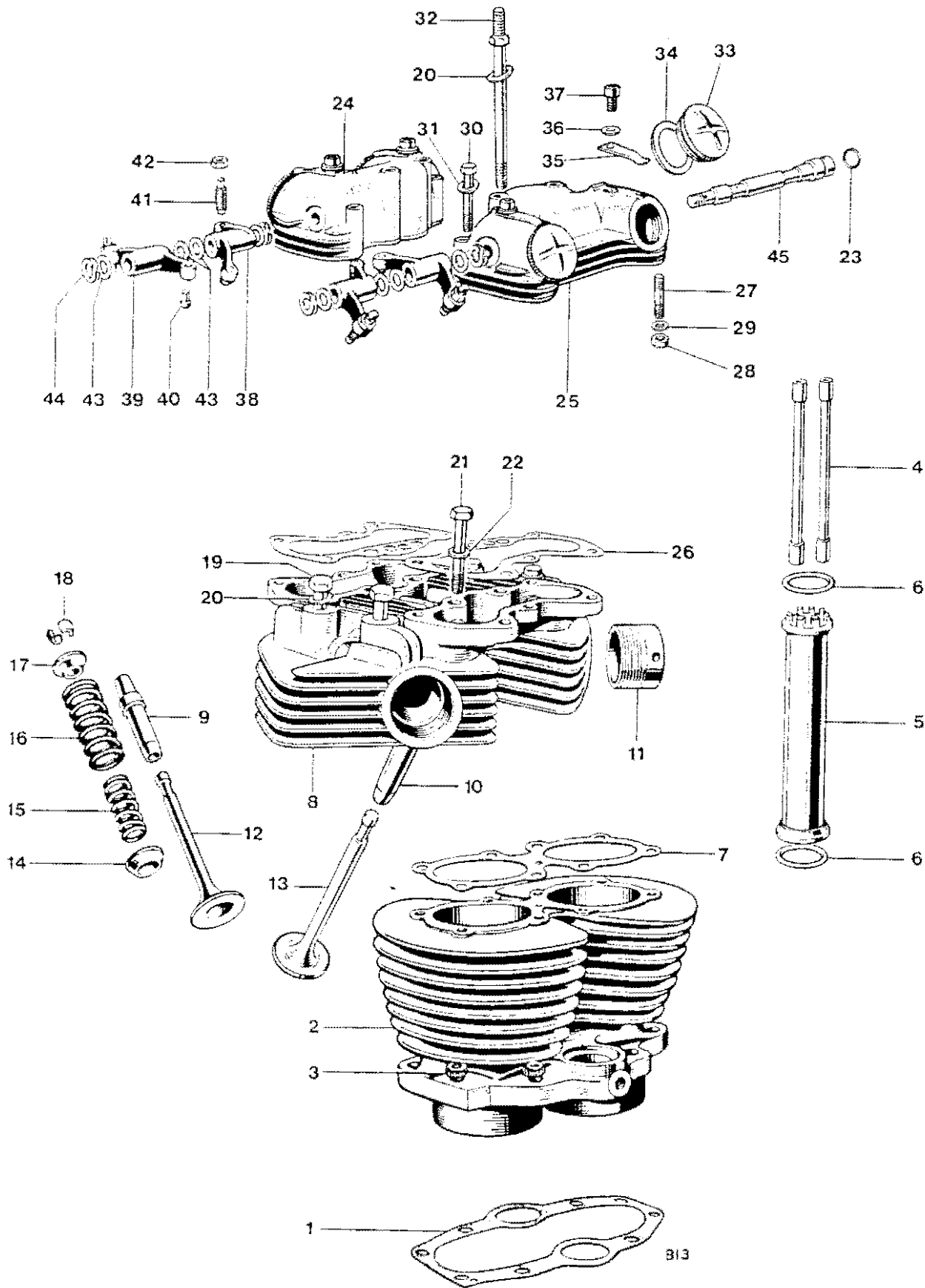
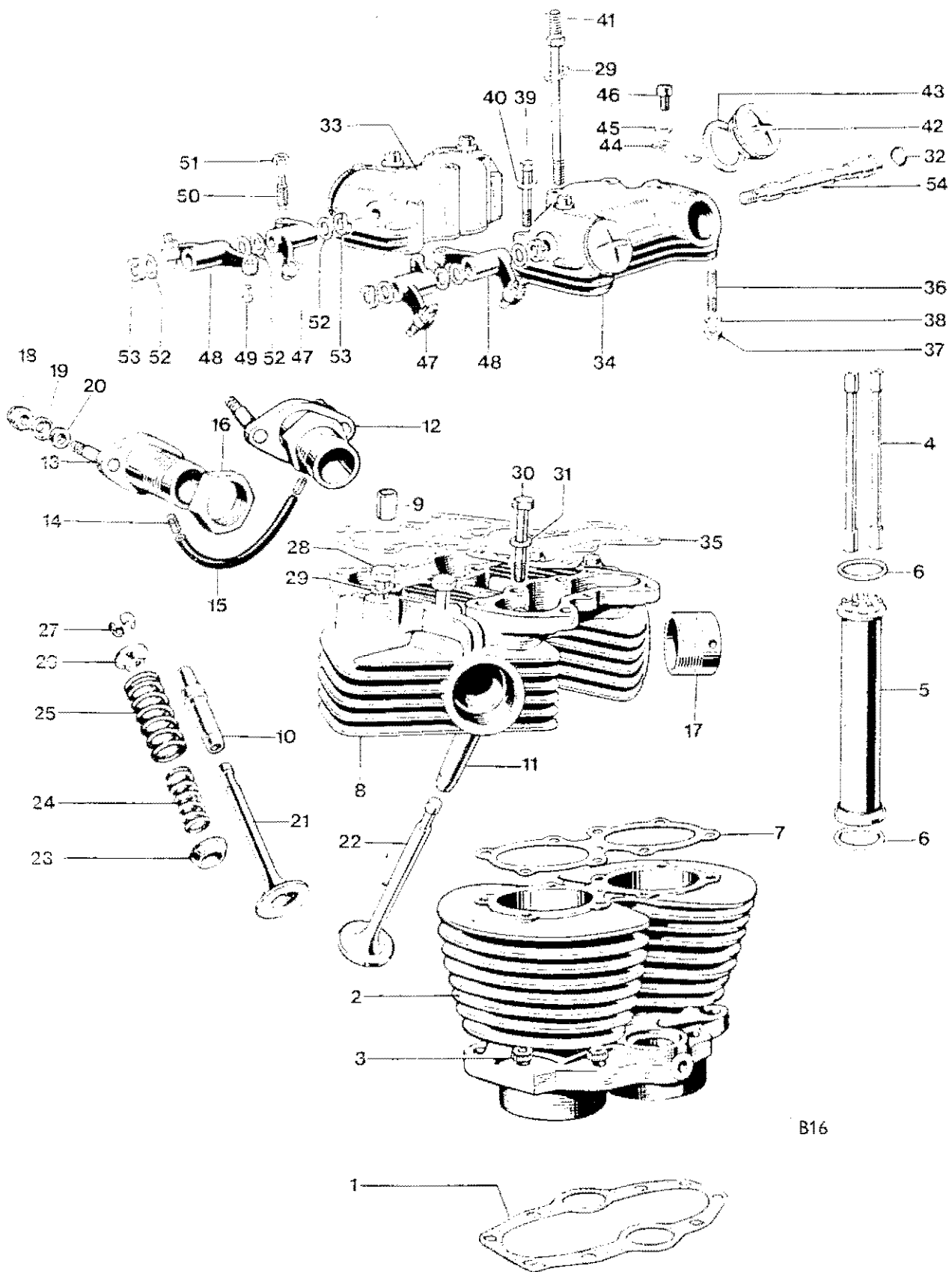

Fig. 4. CYLINDER BLOCK AND HEAD, TR6

Ref. No.	Part No.	DESCRIPTION	QUANTITY	REMARKS
----------	----------	-------------	----------	---------

**CYLINDER BLOCK AND HEAD, TR6R, TR6C**

1	E6309	Cylinder base washer ... ..	1	
2	E6304	Cylinder block ... ..	1	
3	S692	Cylinder base nut ... ..	8	
4	E2620	Push rod ... ..	4	
5	E9349	Cover tube ... ..	2	
6	E7310	"O" ring ... ..	4	
7	E4547	Cylinder head gasket ... ..	1	
8	E9362	CYLINDER HEAD c/w GUIDES ... ..	1	
9	E2899	Inlet valve guide ... ..	2	
10	E2900	Exhaust valve guide ... ..	2	
11	E9516	Exhaust pipe adaptor ... ..	2	
12	E4603	Inlet valve ... ..	2	
13	E2904	Exhaust valve ... ..	2	
14	E6439	Bottom cup ... ..	4	
15	E4221	Inner valve spring (red spot) ... ..	4	
16	E7400	Outer valve spring (green spot) ... ..	4	
17	E1543	Top collar ... ..	4	
18	99-0062	Split cotter ... ..	8	
19	E327	Cylinder head bolt (3 $\frac{3}{8}$ in. U.H.) ... ..	4	
20	F2184	Plain washer ... ..	8	
21	E4771	Bolt (3 in. U.H.) ... ..	1	
22	S25-3	Plain washer ... ..	1	
23	E3253	Sealing ring ... ..	2	
24	E4550	Inlet rocker box ... ..	1	
25	E4551	Exhaust rocker box ... ..	1	
26	E9348	Joint washer ... ..	2	
27	E2980	Rocker box stud ( $\frac{15}{16}$ in. O.A.) ... ..	6	
28	F879	Rocker box nut ... ..	6	
29	E3302	Plain washer ... ..	6	
30	S1875	Rocker box bolt (2 $\frac{5}{32}$ in. U.H.) ... ..	4	
31	S25-13	Plain washer ... ..	4	
32	E1596A	Cylinder head bolt (for torque stay) ... ..	4	
33	E4610	Inspection cap ... ..	4	
34	E3751	Joint washer ... ..	4	
35	E4609	Locking spring ... ..	4	
36	WE170	Fibre washer ... ..	4	
37	T1553	Screw ( $\frac{3}{8}$ in. U.H.) ... ..	4	
38	E1457	ROCKER (right exhaust, left inlet) ... ..	2	
39	E1458	ROCKER (left exhaust, right inlet) ... ..	2	
40	E10070	Rocker ball pin ... ..	4	
41	E1513	Rocker adjusting pin ... ..	4	
42	E470	Adjuster lock nut ... ..	4	
43	E1575	Thrust washer, $\frac{1}{2}$ in. ... ..	8	
44	E1574	Spring washer ... ..	4	
45	E1512	Rocker spindle ... ..	2	



B16

Fig. 5. CYLINDER BLOCK AND HEAD, T120



Ref. No.	Part No.	DESCRIPTION	QUANTITY	REMARKS
<b>CYLINDER BLOCK AND HEAD, T120R</b>				
1	E6309	Cylinder base washer ... ..	1	
2	E6304	Cylinder block ... ..	1	
3	S692	Cylinder base nut ... ..	8	
4	E2620	Push rod ... ..	4	
5	E9349	Cover tube ... ..	2	
6	E7310	"O" ring ... ..	4	
7	E4547	Cylinder head gasket ... ..	1	
8	E9418	CYLINDER HEAD c/w GUIDES ... ..	1	
9	E5347	Sleeve for head bolts passing through inlet tracts ... ..	2	Reference only
10	E3827	Inlet valve guide ... ..	2	
11	E3828	Exhaust valve guide ... ..	2	
12	E9550	Carburetor adaptor, left ... ..	1	
13	E9551	Carburetor adaptor, right ... ..	1	
14	E6916	Connector ... ..	2	
15	E4792	Balance pipe ... ..	1	
16	S1932	Adaptor locking nut ... ..	2	
17	E9516	Exhaust pipe adaptor ... ..	2	
18	14-1301	Self-locking nut ... ..	4	
19	E9555	Cup ... ..	4	
20	E9554	Insulating ring ... ..	4	
21	E4603	Inlet valve ... ..	2	
22	E2904	Exhaust valve ... ..	2	
23	E6439	Bottom cup ... ..	4	
24	E4221	Inner valve spring (Red spot) ... ..	4	
25	E7400	Outer valve spring (green spot) ... ..	4	
26	E1543	Top collar ... ..	4	
27	99-0062	Split cotter ... ..	8	
28	E327	Cylinder head bolt (3 $\frac{3}{8}$ in. U.H.) ... ..	4	
29	F2184	Plain washer ... ..	8	
30	E4771	Bolt (3 in. U.H.) ... ..	1	
31	S25-3	Plain washer ... ..	1	
32	E3253	Sealing ring ... ..	2	
33	E4550	Inlet rocker box ... ..	1	
34	E4551	Exhaust rocker box ... ..	1	
35	E9348	Joint washer ... ..	2	
36	E2980	Rocker box stud ( $1\frac{5}{8}$ in. O.A.) ... ..	6	
37	F879	Nut ... ..	6	
38	E3302	Plain washer ... ..	6	
39	S1875	Rocker box bolt (2 $\frac{5}{32}$ in. U.H.) ... ..	4	
40	S25-13	Plain washer ... ..	4	
41	E1596A	Cylinder head bolt (for torque stay) ... ..	4	
42	E4610	Inspection cap ... ..	4	
43	E3751	Joint washer ... ..	4	
44	E4609	Locking spring ... ..	4	
45	WE170	Fibre washer ... ..	4	
46	T1553	Screw ( $\frac{5}{8}$ in. U.H.) ... ..	4	
47	E1457	ROCKER (right exhaust, left inlet) ... ..	2	
48	E1458	ROCKER (left exhaust, right inlet) ... ..	2	
49	E10070	Rocker ball pin ... ..	4	
50	E1513	Rocker adjusting pin ... ..	4	
51	E470	Adjuster lock nut ... ..	4	
52	E1575	Thrust washer, $\frac{1}{2}$ in. ... ..	8	
53	E1574	Spring washer ... ..	4	
54	E1512	Rocker spindle ... ..	2	

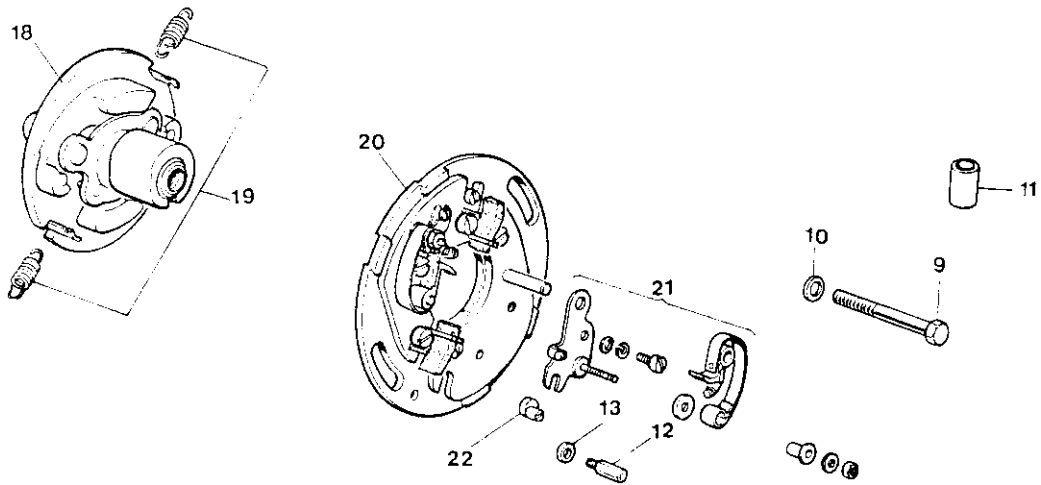
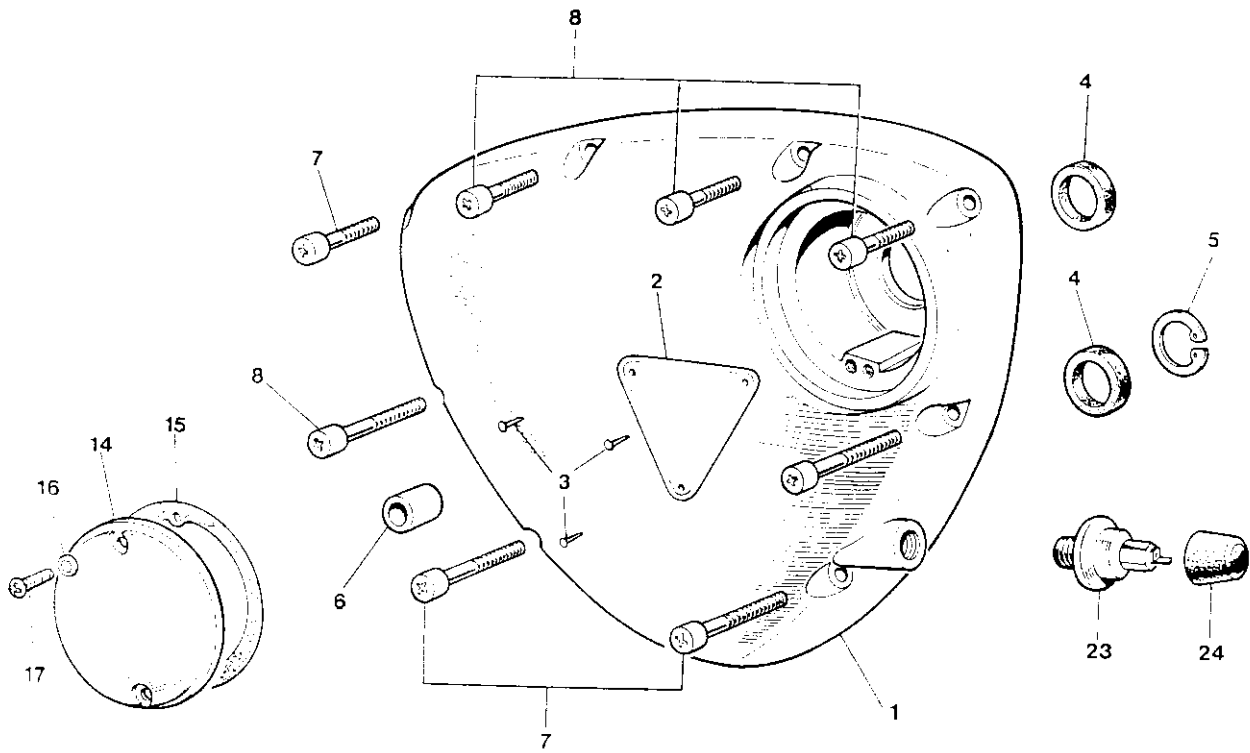

Fig. 6. TIMING COVER AND CONTACT BREAKER

B25

Ref. No.	Part No.	DESCRIPTION	QUANTITY	REMARKS
<b>TIMING COVER AND CONTACT BREAKER</b>				
1	E9246	Timing cover ... ..	1	
2	E4016	Patent plate ... ..	1	
3	D208-5	Hammer-drive screw ... ..	3	
4	E4568	Oil seal ... ..	2	
4	E6387	Oil seal (0.020 in. undersize) ... ..	1	For reground crankshaft
5	E4569	Circlip ... ..	1	
6	T989	Hollow dowel ... ..	1	
7	14-6609	Screw (1½ in. U.H.) ... ..	3	
8	14-6608	Screw (1 in. U.H.) ... ..	5	
9	E8828	Bolt (2 in. U.H.)... ..	1	
10	S25-43	Plain washer ... ..	1	
11	E4707	Rubber grommet ... ..	1	
12	E7680	Pillar bolt ... ..	2	
13	E6559	Plain washer ... ..	2	
14	E8737	Cover ... ..	1	
15	E5049	Joint washer ... ..	1	
16	GS299	Serrated washer ... ..	2	
17	E7354	Screw (½ in. U.H.) ... ..	2	
18	54419340	AUTO ADVANCE UNIT (99-0771) ... ..	1	
19	54415642	Spring set (99-0757) ... ..	1	
20	54419097	CONTACT BREAKER PLATE ASSEMBLY (99-0768) ... ..	1	
21	54419827	Contact set (99-0772) ... ..	2	
22	54419220	Pin, adjustment (99-0769) ... ..	2	
Not illus.	E4849	Dowel pin for auto advance ... ..	1	
23	*D2133	Oil pressure switch ... ..	1	
24	D2045	Cover pressure switch ... ..	1	
Not illus.	D2138	Timing label for C.B. cover ... ..	1	

\* E9526 Blanking plug available to replace oil switch if required

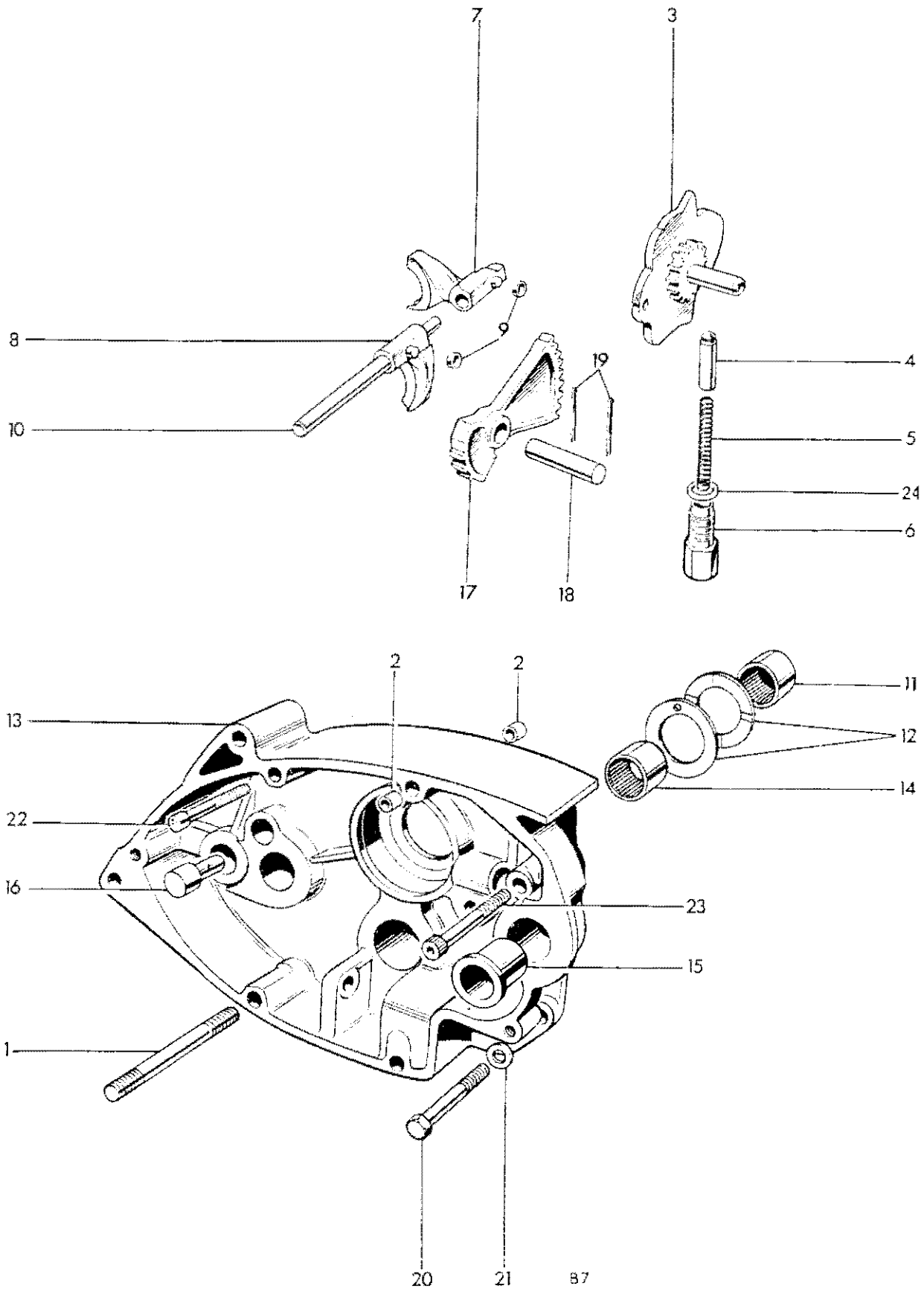

Fig. 7. GEARBOX INNER COVER AND SELECTORS

**GEARBOX INNER COVER AND SELECTORS**

1	14-1427	Stud (3 in. O.A.)	2	
2	T989	Hollow dowel	4	
3	T4055	Gear selector camplate	1	
4	T3660	Camplate index plunger	1	
5	T4059	Index plunger spring	1	
5	T1604	Strong index plunger spring	as required	
6	T2172	Index plunger holder	1	
7	T2596	Mainshaft selector fork	1	
8	T913	Layshaft selector fork	1	
9	NT261	Selector fork roller	2	
10	T3989	Selector fork rod	1	
11	T1606	Layshaft bearing	1	
12	T1607	Thrust washer	2	
13	T3766	<b>GEARBOX INNER COVER</b>	1	
14	T1614	Layshaft bearing	1	
15	T412	Gearchange spindle bush	1	
16	T45	Kickstarter stop	1	
17	T397	Camplate operating quadrant	1	
18	T1896	Quadrant spindle	1	
19	—	Split pin $\frac{5}{16}$ in. x $1\frac{3}{8}$ in.	Reference only	
20	S1907	Bolt ( $1\frac{1}{8}$ in. U.H.)	1	
21	E3446	Plain washer	1	
22	14-6608	Screw (1 in. U.H.)	1	
23	14-7023	Socket screw ( $1\frac{3}{4}$ in. U.H.)	1	
24	T3978	Washer	1	

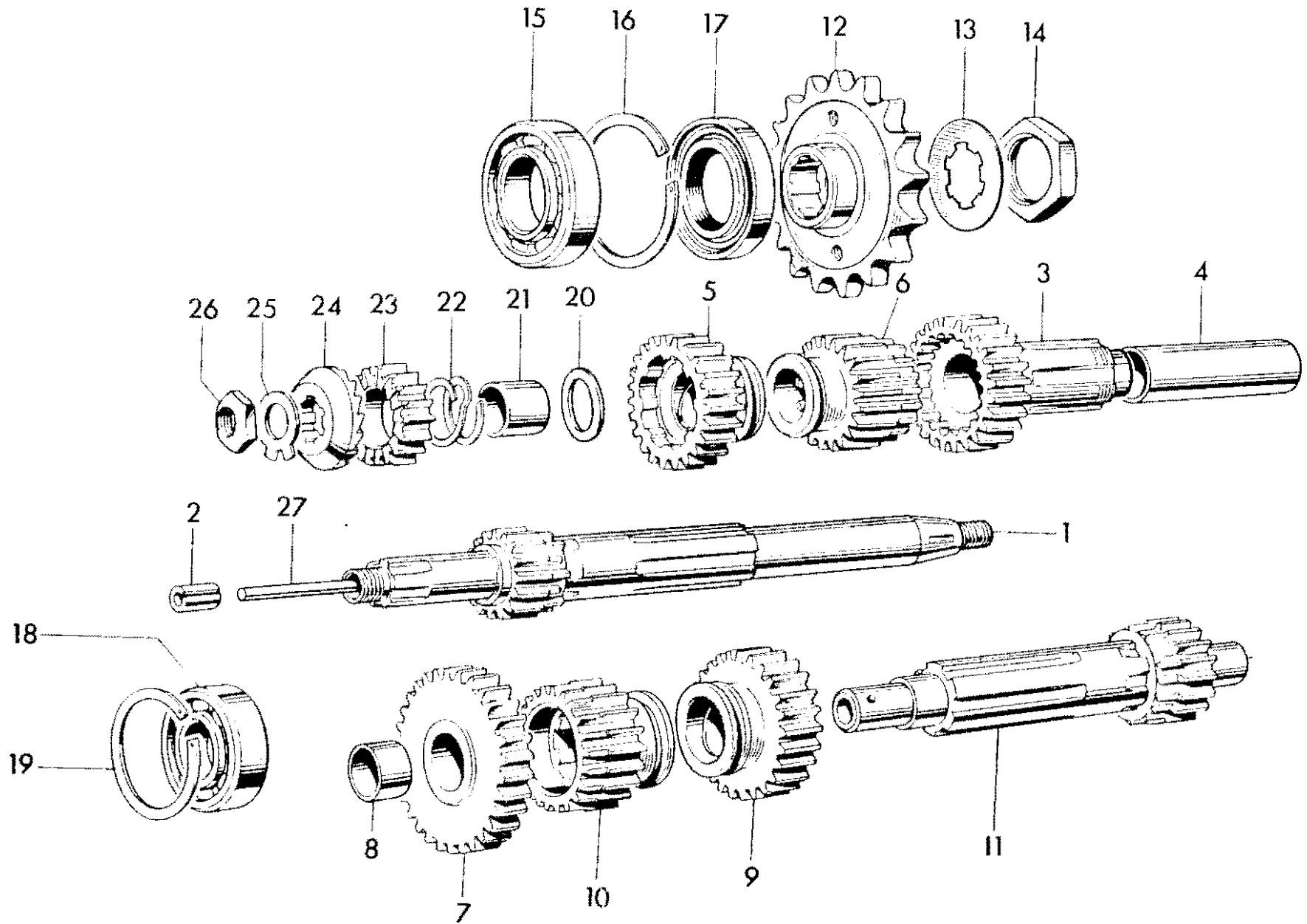

Fig. 8. GEARBOX SHAFTS AND GEARS

**GEARBOX SHAFTS AND GEARS**

1	T3893	MAINSHAFT c/w LOW GEAR (16T)	...	...	...	...	1
2	T3988	Clutch rod bush	...	...	...	...	1
3	T3891	MAINSHAFT HIGH GEAR (26T)	...	...	...	...	1
4	T1370	High gear bush	...	...	...	...	1
5	T3889	Mainshaft third gear (23T)	...	...	...	...	1
6	T3857	Mainshaft second gear (20T)	...	...	...	...	1
7	T3862	LAYSHAFT LOW GEAR (30T)	...	...	...	...	1
8	T928	Low gear bush	...	...	...	...	1
9	T3861	Layshaft second gear (26T)	...	...	...	...	1
10	T3890	Layshaft third gear (22T)	...	...	...	...	1
11	T3864	Layshaft c/w high gear (20T)	...	...	...	...	1
12	T1952	Gearbox sprocket (15 teeth)	...	...	...	...	1
12	T1953	Gearbox sprocket (16 teeth)	...	...	...	...	1
12	T1916	Gearbox sprocket (17 teeth)	...	...	...	...	1
12	T1917	Gearbox sprocket (18 teeth)	...	...	...	...	1
12	T1918	Gearbox sprocket (19 teeth)	...	...	...	...	1
12	T1919	Gearbox sprocket (20 teeth)	...	...	...	...	1
13	T2116	Tab washer	...	...	...	...	1
14	T440	Gearbox sprocket nuc	...	...	...	...	1
15	T448	High gear bearing	...	...	...	...	1
16	E489	Circlip	...	...	...	...	1
17	T946	Oil seal	...	...	...	...	1
18	S35-7	Mainshaft bearing	...	...	...	...	1
19	T280	Circlip	...	...	...	...	1
20	T1962	Plain washer	...	...	...	...	1
21	T1963	Pinion sleeve	...	...	...	...	1
22	T1250	Pinion spring	...	...	...	...	1
23	T730	Kickstarter pinion	...	...	...	...	1
24	T731	Kickstarter ratchet	...	...	...	...	1
25	T2240	Tab washer	...	...	...	...	1
26	S594	Nuc	...	...	...	...	1
27	T1736	Clutch operating rod	...	...	...	...	1

See pages 6 to 8 for standard sizes

**WIDE RATIO GEARS**

3	T2530	MAINSHAFT HIGH GEAR (28T)	...	...	...	...	1
6	T968	Mainshaft second gear (19T)	...	...	...	...	1
9	T974	Layshaft second gear (27T)	...	...	...	...	1
11	T1844	Layshaft c/w high gear (18T)	...	...	...	...	1

**CLOSE RATIO GEARS**

1	T2438	MAINSHAFT c/w LOW GEAR (18T)	...	...	...	...	1
3	T2528	MAINSHAFT HIGH GEAR (24T)	...	...	...	...	1
5	T1179	Mainshaft third gear (23T)	...	...	...	...	1
6	T955	Mainshaft second gear (21T)	...	...	...	...	1
7	T961	LAYSHAFT LOW GEAR (28T)	...	...	...	...	1
9	T963	Layshaft second gear (25T)	...	...	...	...	1
10	T964	Layshaft third gear (23T)	...	...	...	...	1
11	T1845	Layshaft c/w high gear (22T)	...	...	...	...	1

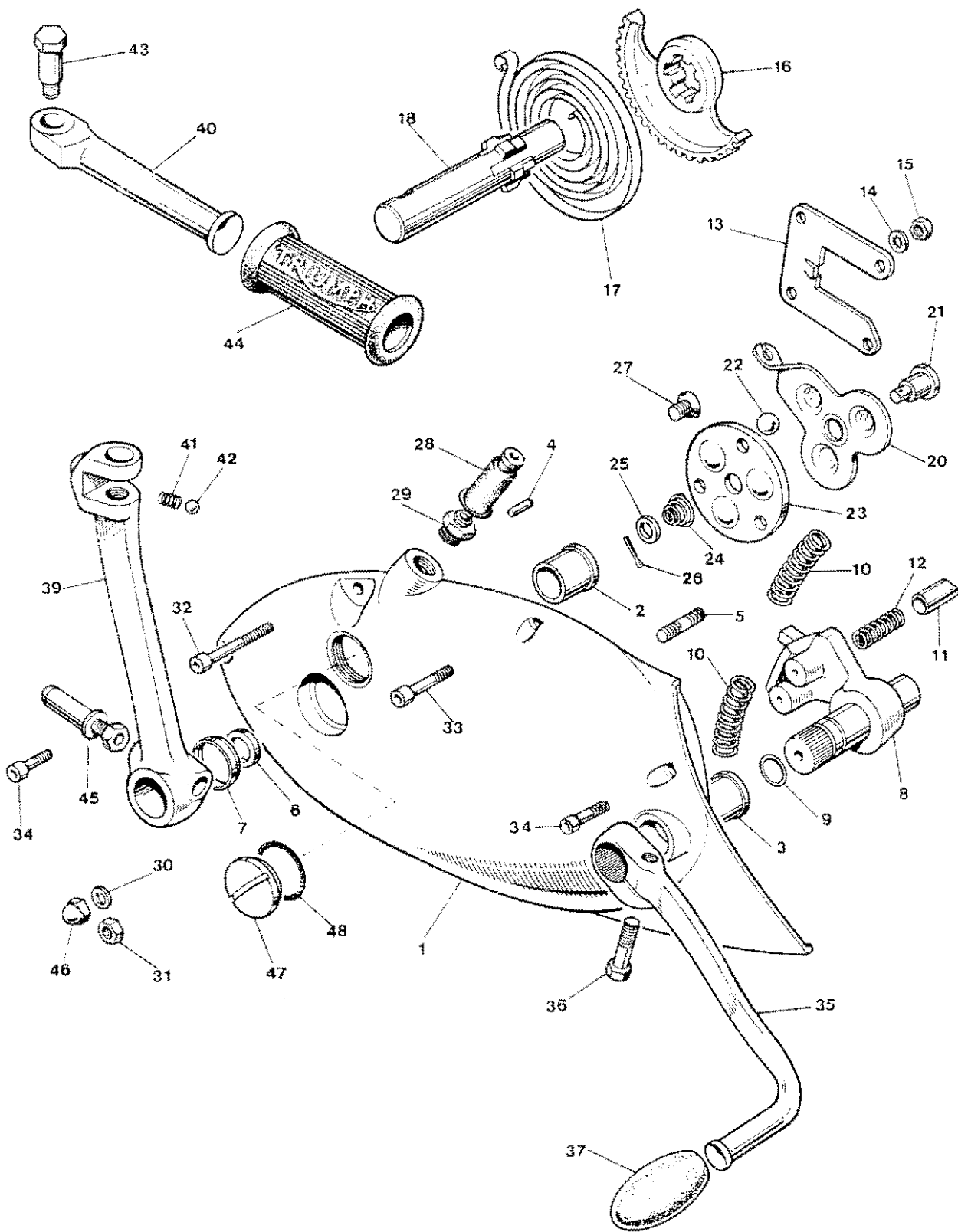

Fig. 9. GEARBOX OUTER COVER



Ref. No.	Part No.	DESCRIPTION	QUANTITY	REMARKS
<b>GEARBOX OUTER COVER</b>				
1	T3760	GEARBOX OUTER COVER	1	
2	T23	Kickstarter spindle bush	1	
3	T57	Gearchange spindle bush	1	
4	T47	Kickstarter spring anchor pin	1	
5	S547	Guide plate stud ( $\frac{7}{8}$ in. O.A.)	4	
6	T1956	Oil seal	1	
7	T1955	Oil seal housing	1	
8	T408/9	Gearchange quadrant	1	
9	E3309	Rubber "O" ring	1	
10	T404	Quadrant return spring	2	
11	T406	Gearchange quadrant plunger	2	
12	T405	Plunger spring	2	
13	T407	Guide plate	1	
14	E1612	Serrated washer	4	
15	14-0301	Nut	4	
16	T25A	Kickstarter quadrant	1	
17	T31	Kickstarter return spring	1	
18	T24A	Kickstarter axle	1	
19	T3629	CLUTCH LEVER ASSEMBLY	1	
20	T2191	Clutch lever	1	
21	T1710	Lever shaft	1	
22	T1771	Ball, $\frac{3}{8}$ in. diam.	3	
23	T3761	Thrust plate	1	
24	T1712	Return spring	1	
25	GS127	Plain washer	1	
26	—	Split pin ( $\frac{5}{64}$ in. x $\frac{1}{2}$ in.)	1	Reference only
27	S1879	Countersunk screw ( $\frac{13}{32}$ in. O.A.)	2	
28	T1646	Rubber cover	1	
29	T3762	Abutment for clutch cable	1	
30	S25-3	Plain washer	2	
31	14-0302	Nut	1	
32	S1878	Screw ( $2\frac{3}{4}$ in. U.H.)	2	
33	14-6609	Screw ( $1\frac{5}{16}$ in. U.H.)	2	
34	14-6608	Screw (1 in. U.H.)	1	
35	T3757	Gearchange pedal	1	
36	14-0201	Bolt (1 in. U.H.)	1	
37	T2450	Pedal rubber	1	
38	T3632	FOLDING KICKSTARTER	1	
39	T2173	Kickstarter lever	1	
40	T1272	Kickstarter pedal	1	
41	T1167	Pedal locating spring	1	
42	S70-3	Steel ball, $\frac{1}{4}$ in. diam.	1	
43	S541	Pedal bolt	1	
44	T2330	Pedal rubber	1	
45	T1222	Cotter pin c/w nut and washer	1	
46	S544	Domed nut	1	
47	T2166	Filler plug	1	
48	E8782	"O" ring	1	

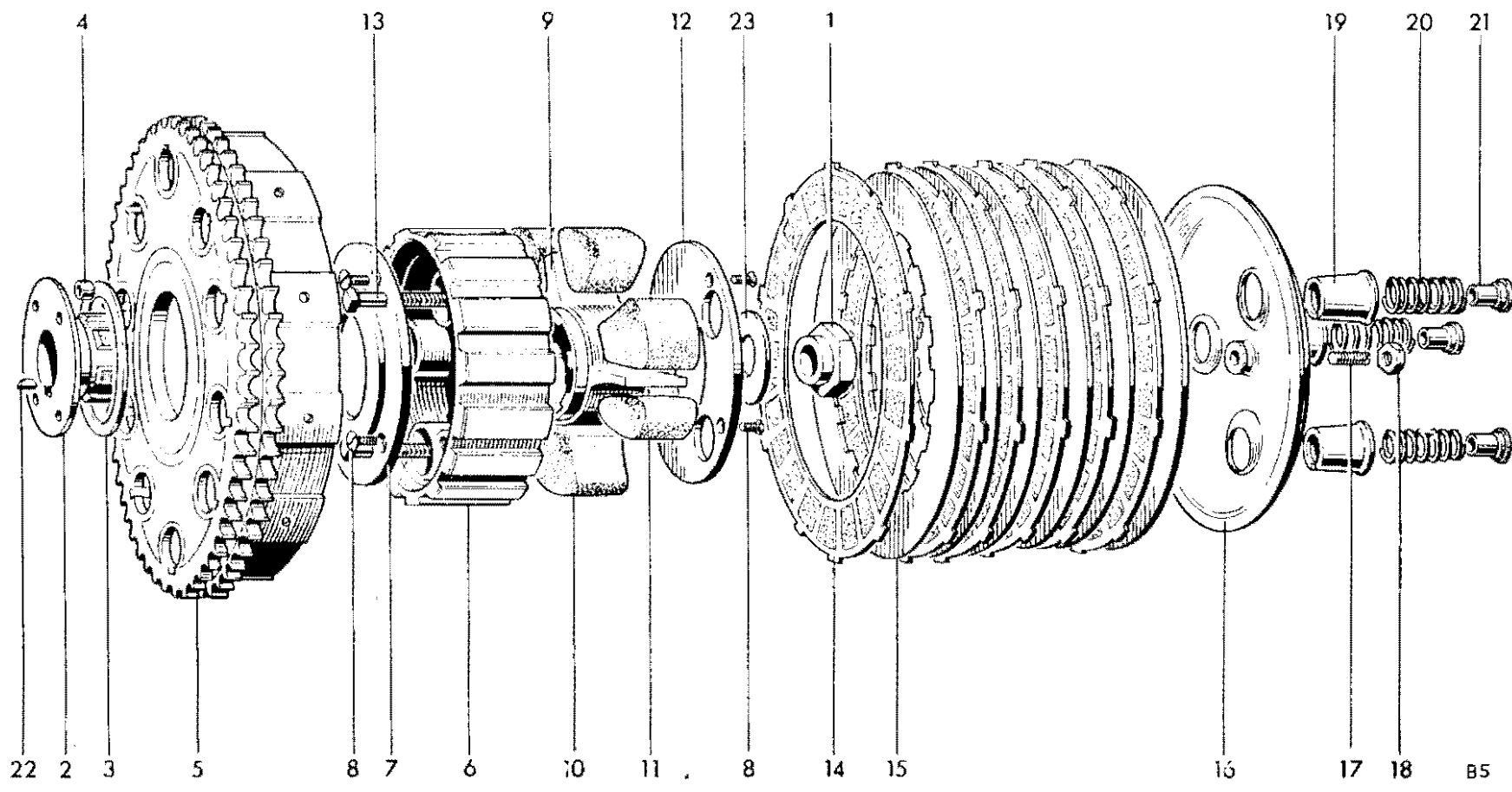

Fig. 10. CLUTCH

Ref. No.	Part No.	DESCRIPTION	QUANTITY	REMARKS
<b>CLUTCH</b>				
1	S586	Clutch securing nut ... ..	1	
2	T3929	Hub ... ..	1	
3	T2931	Thrust washer ... ..	1	
4	T394	Roller ... ..	20	
5	T1570	Sprocket and housing (58 teeth Duplex) ... ..	1	
6	T1719	Centre ... ..	1	
7	T1720	Inner plate ... ..	1	
8	T1040	Countersunk screw (0.417 in. U.H.) ... ..	6	
9	T2538	Shock absorber spider ... ..	1	
10	T1722	Drive rubber (large) ... ..	3	
11	T1723	Rebound rubber (small) ... ..	3	
12	T1724	Outer plate ... ..	1	
13	T423A	Screwed pin ( $1\frac{27}{32}$ in. U.H.) ... ..	3	
14	T1362	Driving plate (bonded) ... ..	6	
15	T1363	Driven plate ... ..	6	
16	T2156	Pressure plate ... ..	1	
17	T2159	Adjuster pin ... ..	1	
18	14-0403	Nut ... ..	1	
19	T1931	Spring cup ... ..	3	
20	T1830	Spring ... ..	3	
21	T2526	Pressure nut ... ..	3	
22	S66-1	Key ... ..	1	
23	T2279	Cupped washer ... ..	1	

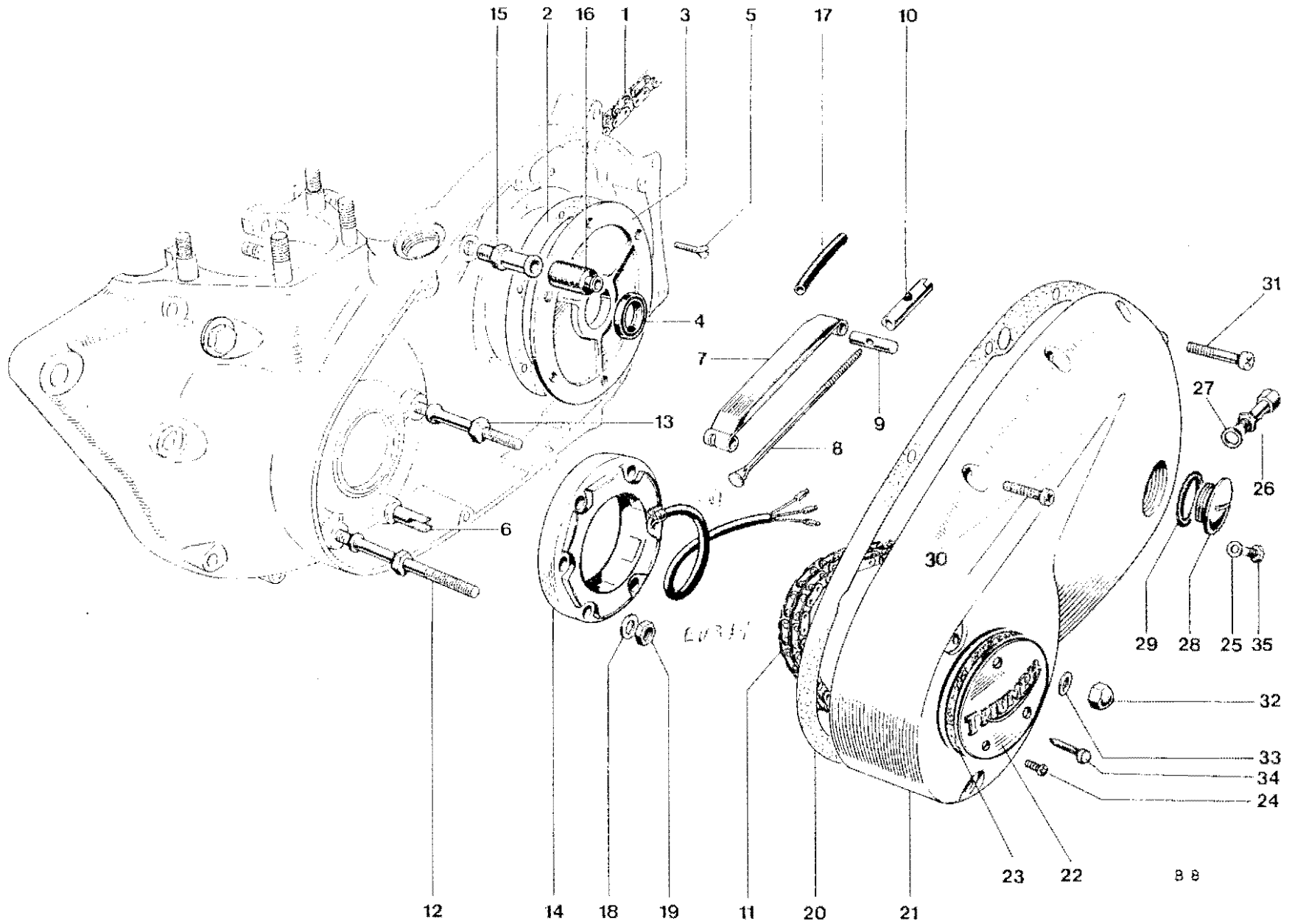

Fig. 11. CHAINCASE AND CHAINS

**CHAINCASE AND CHAINS**

1	D530	Rear chain, $\frac{5}{8}$ in. x $\frac{3}{8}$ in. x 104 links ...	1	
2	E3832	Joint washer ...	1	
3	E7037	Cover plate ...	1	
4	E7565	Oil seal ...	1	
5	E3821	Countersunk screw ( $\frac{5}{16}$ in. U.H.) ...	6	
6	E5976	Chain tensioner abutment ...	1	
7	E6061	Chain tensioner blade ...	1	
8	E4152	Tie rod ...	1	
9	E5977	Trunnion ...	1	
10	E9703	Adjuster sleeve nut ...	1	
11	D477	Primary chain, $\frac{3}{8}$ in. Duplex x 84 links ...	1	
12	S1866	Stator stud ( $4\frac{1}{2}$ in. O.A.) ...	2	
13	S1867	Stator stud ...	1	
14	47205	Stator, RM21 (99-1006) ...	1	
15	E8992	Sleeve nut ...	1	
16	E4144	Rubber grommet ...	1	
17	E5449	Plastic sleeve ...	1	
18	S25-3	Plain washer ...	3	
19	14-0702	Self-locking nut ...	3	
20	T1770	Joint washer ...	1	
21	E9245	Chaincase ...	1	
22	T2440	Rotor cover ...	1	
23	T2442	Joint washer ...	1	
24	F4129	Screw ...	3	
25	E2441	Copper washer ...	1	
26	T2259	Drain and adjuster plug ...	1	
27	T1738	Fibre washer ...	1	
28	T2166	Filler plug ...	1	
29	E8782	"O" ring ...	1	
30	14-6608	Screw (1 in. U.H.) ...	6	
31	14-6620	Screw ( $\frac{3}{32}$ in. U.H.) ...	2	
32	S544	Domed nut ...	2	
33	F1880	Copper washer ...	2	
34	T2443	Timing pointer ...	1	
35	14-6101	Level plug ...	1	

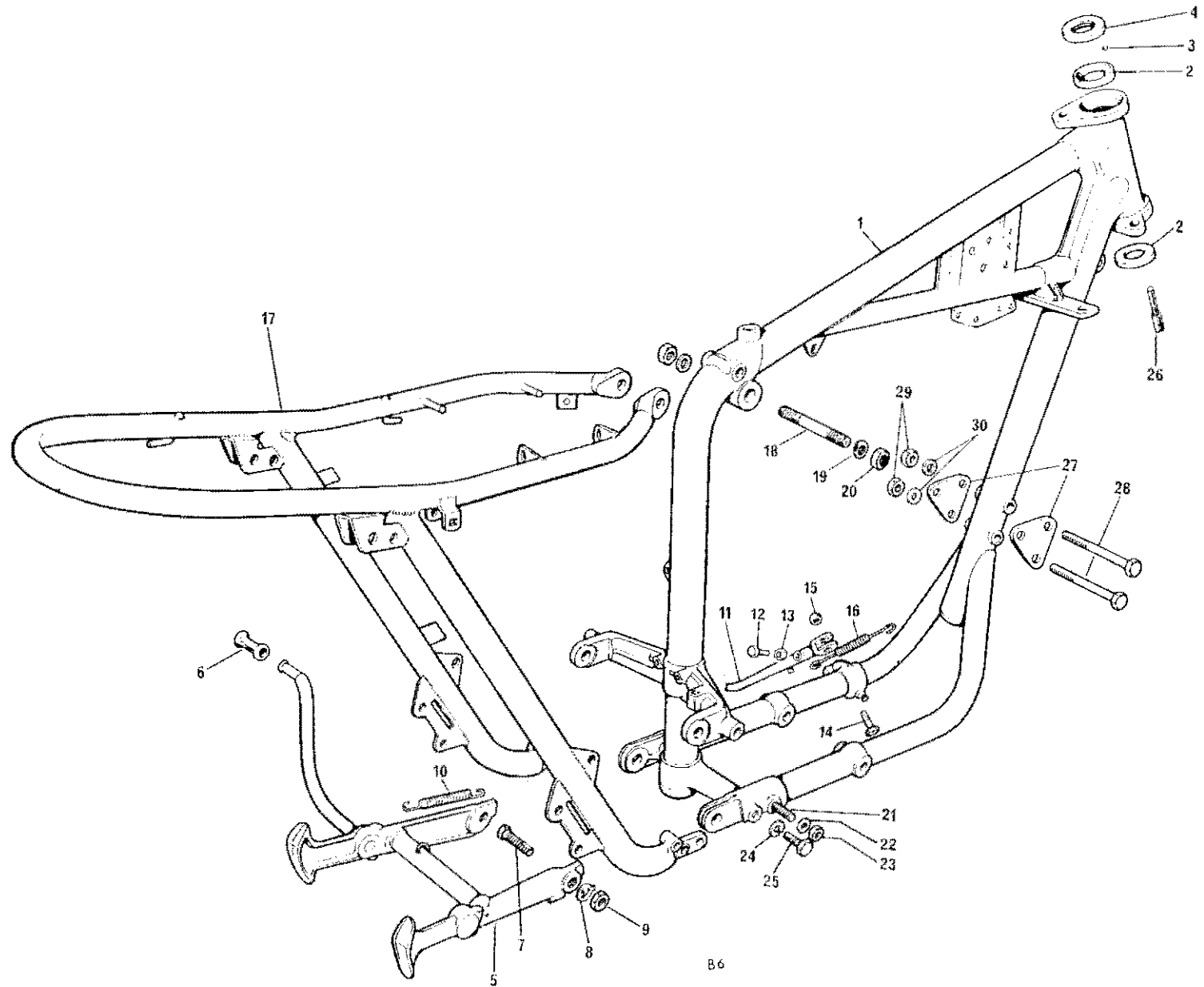

Fig. 12. FRAME

B 6

Ref. No.	Part No.	DESCRIPTION	QUANTITY	REMARKS
<b>FRAME</b>				
1	F11754	Front frame ... ..	1	
2	H111	Steering race cup ... ..	2	
3	S70-3	Steel ball ( $\frac{1}{4}$ in. diam.) ... ..	40	
4	H1018	Top cone and dust cover ... ..	1	
5	F11267	Centre stand ... ..	1	
6	T2331	Pedal rubber ... ..	1	
7	S1978	Pivot bolt ... ..	2	
8	F11270	Tab washer ... ..	2	
9	14-0404	Nut ... ..	2	
10	F4671	Return spring ... ..	1	
11	F11560	Prop stand ... ..	1	
12	14-0216	Bolt ( $1\frac{1}{8}$ in. U.H.) ... ..	1	
13	14-0402	Nut ... ..	1	
14	F7021	Pivot bolt ... ..	1	
15	14-0703	Self locking nut ... ..	1	
16	F8392	Return spring ... ..	1	
17	F8036	Rear frame ... ..	1	
18	S1801	Stud ( $3\frac{7}{8}$ in. O.A.) ... ..	1	
19	S25-2	Plain washer ... ..	2	
20	14-1303	Self locking nut ... ..	2	
21	14-0251	Bolt ( $2\frac{1}{8}$ in. U.H.) ... ..	2	
22	F4370	Plain washer ... ..	2	
23	14-1304	Nut ... ..	2	
24	99-0046	Spring washer ... ..	2	
25	S588	Bolt ( $1\frac{3}{8}$ in. U.H.) ... ..	2	
26	F7155	Steering stop ... ..	2	
27	F11356	Front engine plate ... ..	2	
28	14-0252	Bolt ... ..	2	
29	14-1204	Nut ... ..	2	
30	S25-1	Plain washer ... ..	2	
Not illus.	D2452	Transfer "Safety Standard" ... ..	1	

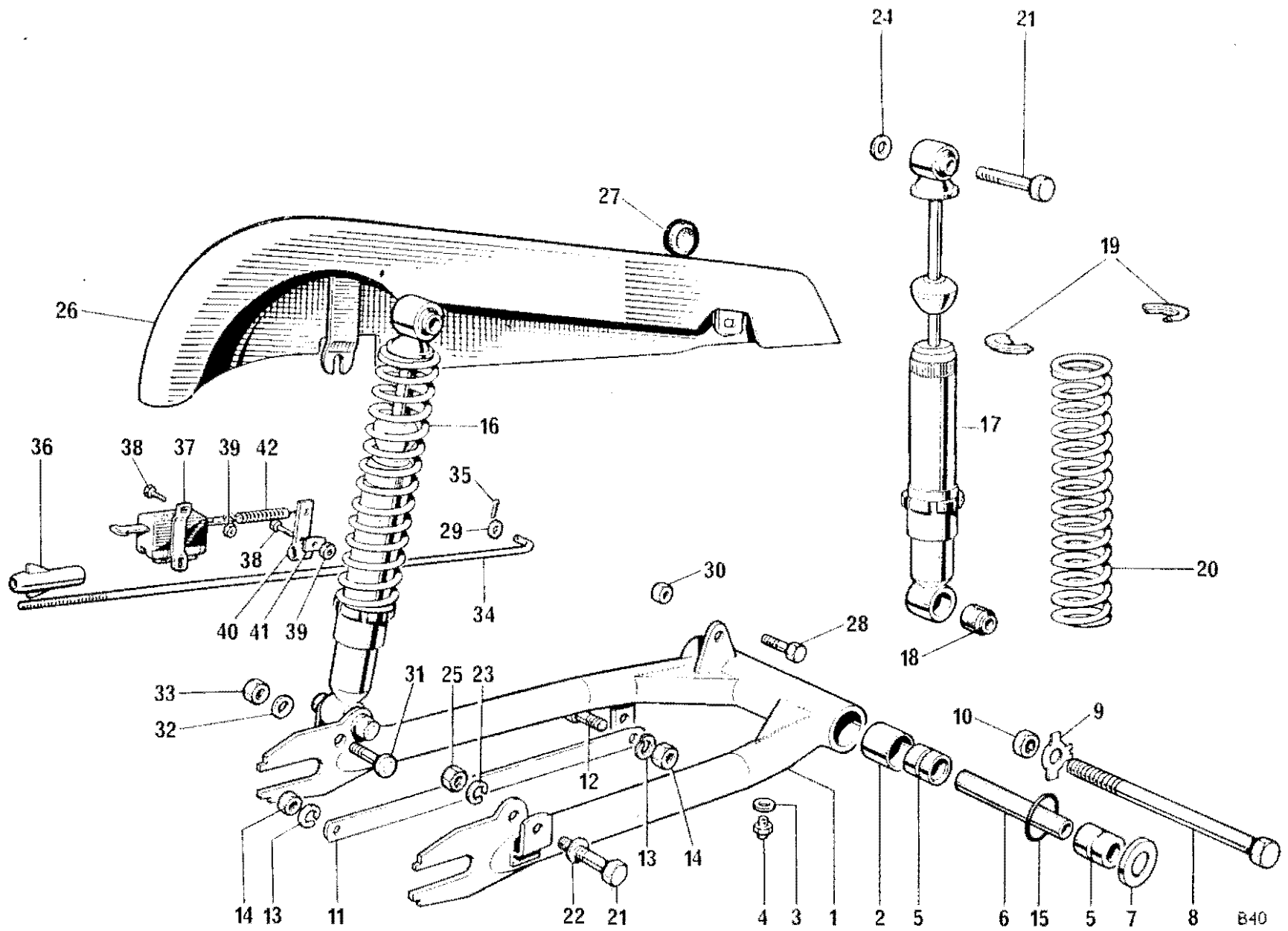

Fig. 13. SWINGING FORK AND SUSPENSION UNITS



### SWINGING FORK AND SUSPENSION UNITS

1	F10045	SWINGING FORK	1	
2	F6042	Pivot bush	2	
3	D1841	Fibre washer	1	
4	WE170	Grease nipple	1	
5	F6821	Sleeve	2	
6	F5313	Distance tube	1	
7	F7848	Flanged washer	2	
8	S620	Bolt ( $8\frac{5}{8}$ in. U.H.)	1	
9	F5944	Tab washer	1	
10	S545	Nut	1	
11	F11564	Brake torque stay	1	
12	S1802	Bolt ( $3\frac{7}{8}$ in. U.H.)	1	
13	99-0046	Spring washer	2	
14	14-0304	Nut	2	
15	F8090	"O" ring	2	
16	D2024	SUSPENSION UNIT (64052107)	2	
17	Reference only	Damper unit (64054465)	2	
18	64533645	Bonded bush (99-0122)	4	
19	9054/171	Spring retainer (99-0107)	4	
20	64543708	Spring 100 lbs. chrome (99-1048)	2	
20	64544234	Spring, 145 lbs. chrome heavy duty (99-1047)	Available	
21	14-0235	Unit fixing bolt ( $1\frac{5}{16}$ in. U.H.)	4	
22	S25-2	Plain washer	2	
23	S26-1	Spring washer	2	
24	S25-2	Plain washer	4	
25	14-0303	Nut	4	
26	F11512	Chainguard	1	
27	F5536	Grommet	1	
28	14-0113	Bolt ( $\frac{9}{16}$ in. U.H.)	1	
29	S25-13	Plain washer	1	
30	14-0702	Self-locking nut	1	
31	F9387	Stepped bolt	1	
32	S25-3	Plain washer	1	
33	14-0302	Nut	1	
34	F7386	Brake operating rod	1	
35	—	Split pin ( $\frac{1}{16}$ in. x $\frac{3}{8}$ in.)	Reference only	
36	F7387	Adjuster nut	1	
37	54033234	Stop lamp switch, type 22B (99-0725)	1	
38	T1076	Screw ( $\frac{3}{8}$ in. U.H.)	3	
39	F4717	Self locking nut	5	
40	F5687	Switch lever	1	
41	F5413	"D" washer	1	
42	F3158	Spring (315738)	1	

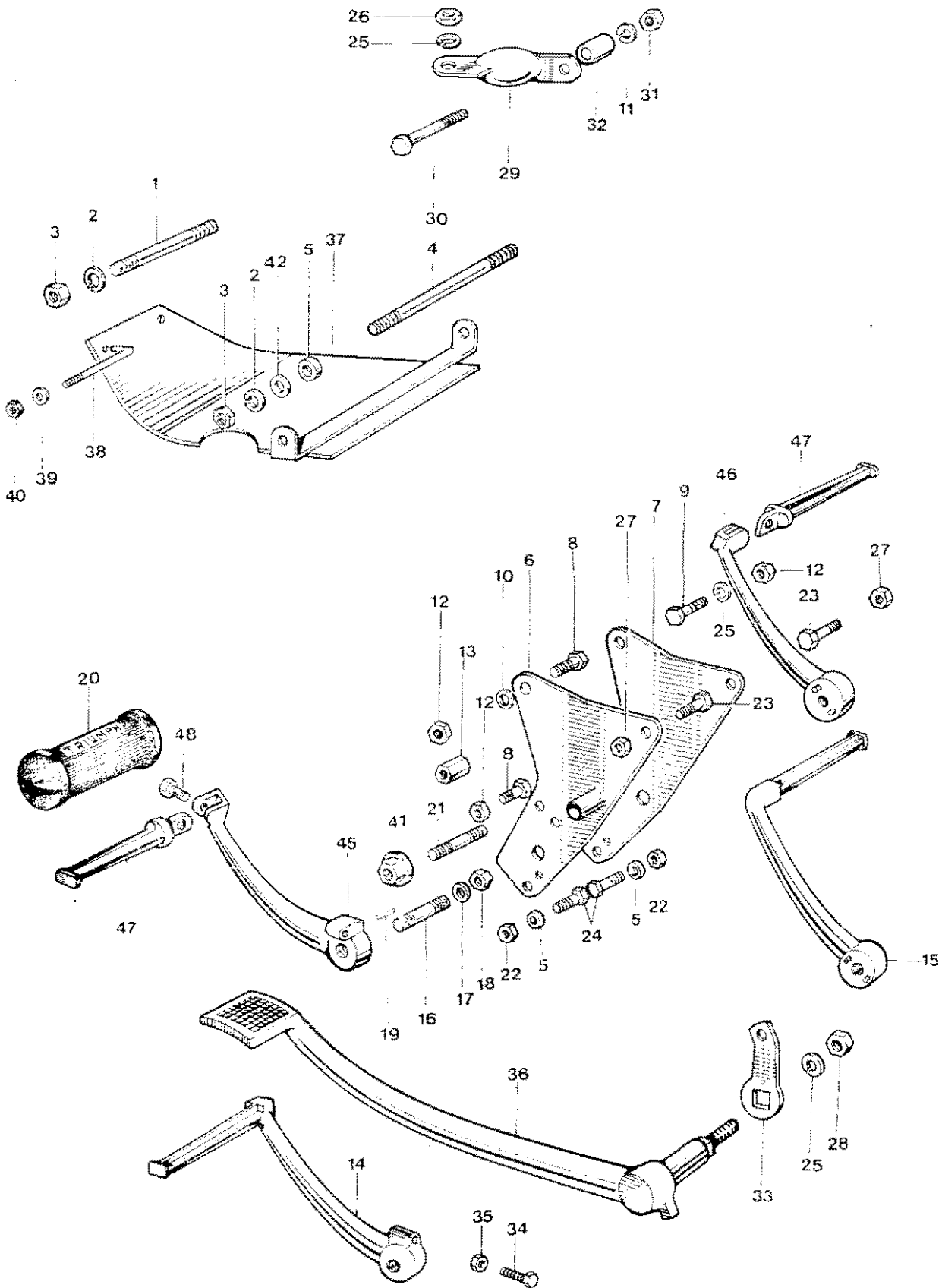

Fig. 14. ENGINE UNIT FITTING AND FOOTRESTS

### ENGINE UNIT FITTINGS AND FOOTRESTS

1	F5469	Stud (3 $\frac{5}{16}$ in. O.A.)	1	
2	99-0046	Spring washer	4	
3	DS47	Nut	4	
4	F6498	Stud (8 $\frac{1}{16}$ in. O.A.)	1	
5	F5532	Distance piece	4	
6	F6066	Left rear engine plate	1	
7	F5908	Right rear engine plate	1	
8	14-0220	Bolt (1 $\frac{3}{4}$ in. U.H.)	2	
9	14-0221	Bolt (2 in. U.H.)	2	
10	S25-3	Plain washer	4	
11	S26-3	Spring washer	6	
12	14-0302	Nut	4	(3 on TR6C)
13	S1933	Extended nut	1	(TR6C only)
14	F9736	Left footrest	1	
15	F9624	Right footrest	1	
16	S1800	Stud (1 $\frac{9}{16}$ in. O.A.)	2	
17	S25-6	Plain washer	2	
18	14-0305	Nut	2	
19	F5943	Peg	4	
20	NF704	Footrest rubber	2	
21	S548	Stud (1 $\frac{3}{8}$ in. O.A.)	2	
22	14-0303	Nut	1	
23	14-0126	Bolt ( $\frac{3}{4}$ in. U.H.)	2	
24	14-0234	Bolt (1 $\frac{3}{4}$ in. U.H.)	2	
25	S26-1	Spring washer	9	
26	S1-52	Nut	4	
27	14-0403	Nut	2	
28	99-0047	Nut	3	
29	E4778	Engine torque stay	4	
30	14-0218	Bolt (1 $\frac{5}{16}$ in. U.H.)	2	
31	14-0302	Nut	2	
32	F3069	Distance piece	4	
33	F6064	Brake pedal lever	1	
34	14-0105	Bolt (1 $\frac{5}{8}$ in. U.H.)	1	
35	14-0401	Nut	1	
36	F6449	Brake pedal	1	
37	F10040	Crankcase undershield...	1	} TR6C
38	F5788	Hook bolt	2	
39	S25-1	Plain washer	2	
40	F879	Nut	2	
41	F7389	Nut	2	
42	F4370	Plain washer	2	} TR6C
43	F11284	LEFT FOOTREST ASSEMBLY	1	
44	F11285	RIGHT FOOTREST ASSEMBLY	1	
45	F11286	Left footrest	1	
46	F11287	Right footrest	1	
47	F6411	Footrest pedal	2	
48	S1971	Pivot bolt	2	

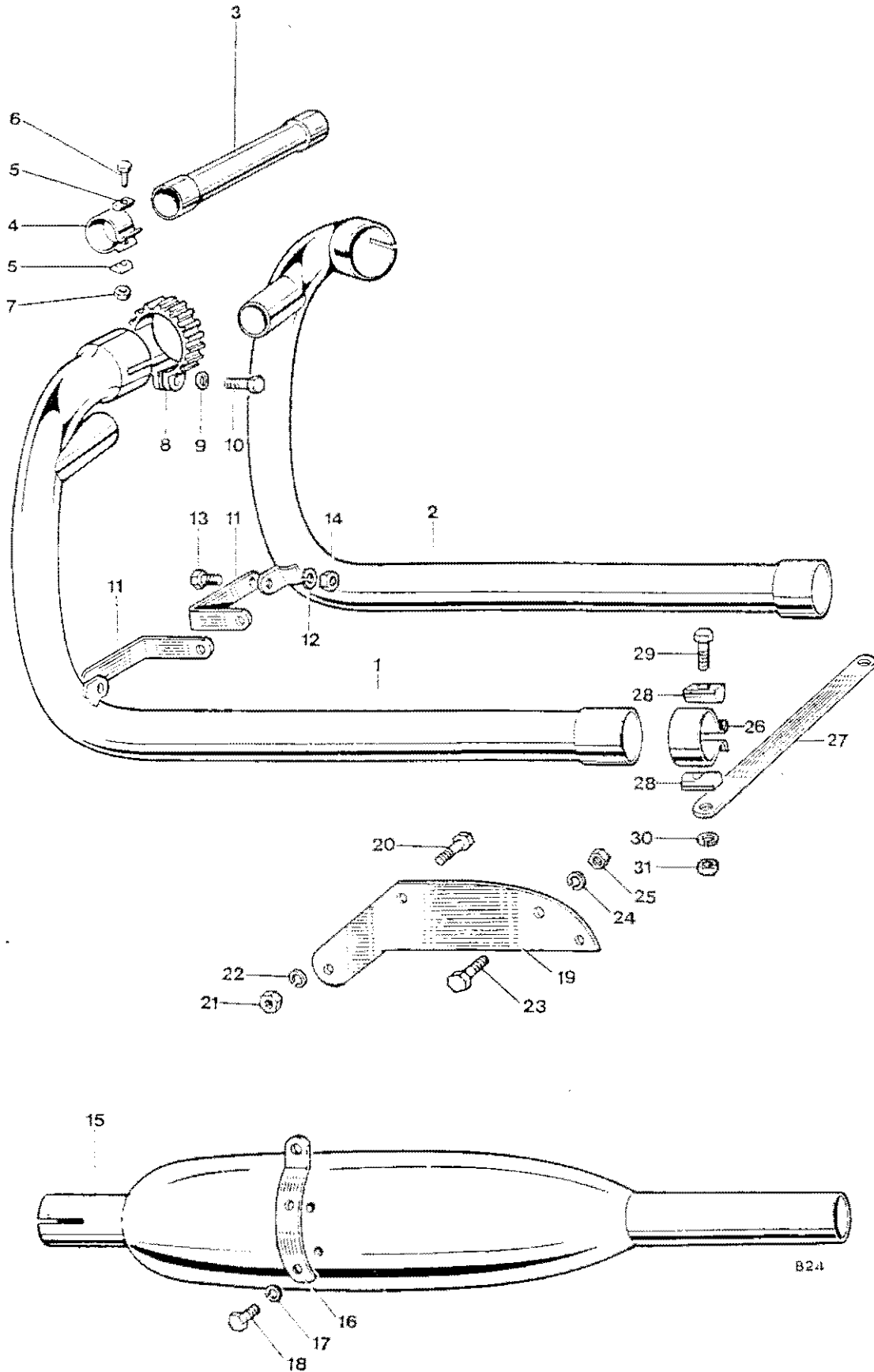

Fig. 15. EXHAUST PIPES AND MUFFLERS T120R, TR6R

## EXHAUST PIPES AND MUFFLERS, T120R, TR6R (See also Page 45)

Ref. No.	Part No.	DESCRIPTION	QUANTITY	REMARKS
1	E9363	EXHAUST PIPE D.S. ... ..	1	
2	E9364	EXHAUST PIPE T.S. ... ..	1	
3	E9888	Coupling pipe ... ..	1	
4	E7512	Clip ... ..	2	
5	E3768	"D" washer ... ..	4	
6	14-0219	Bolt ... ..	2	
7	14-1302	Nut ... ..	2	
8	E10216	Clip, exhaust pipe to head ... ..	2	
9	E8860	Spherical washer clip bolt ... ..	2	
10	E6744	Bolt (for clip) ... ..	2	
11	E6857	Exhaust pipe tie ... ..	2	
12	S26-3	Spring washer ... ..	2	
13	E6179	Screw, stay to exhaust pipe ... ..	2	
14	E7471	Nut, stay to exhaust pipe ... ..	2	
15	E5866	Muffler ... ..	2	
16	E4951	Bracket, silencer bracket ... ..	2	
17	S26-3	Spring washer ... ..	4	
18	F929	Bolt, bracket to silencer ( $\frac{1}{2}$ in. U.H.) ... ..	4	
19	E4711	Hanger, frame for silencer ... ..	2	
20	14-0115	Bolt, silencer hanger to frame ( $\frac{7}{8}$ in. U.H.) ... ..	4	
21	14-0302	Nut ... ..	4	
22	S26-3	Spring washer ... ..	4	
23	14-0114	Bolt, silencer to frame ( $\frac{3}{4}$ in. U.H.) ... ..	2	
24	S26-3	Spring washer ... ..	2	
25	14-0302	Nut ... ..	2	
26	E2271	Clip, silencer to exhaust pipe ... ..	2	
27	E5676	Stay, DS and TS silencers ... ..	1	
28	E3768	"D" washer ... ..	4	
29	14-0219	Bolt ( $1\frac{1}{2}$ in. U.H.) ... ..	2	
30	S26-3	Spring washer ... ..	2	
31	S1908	Nut ... ..	2	

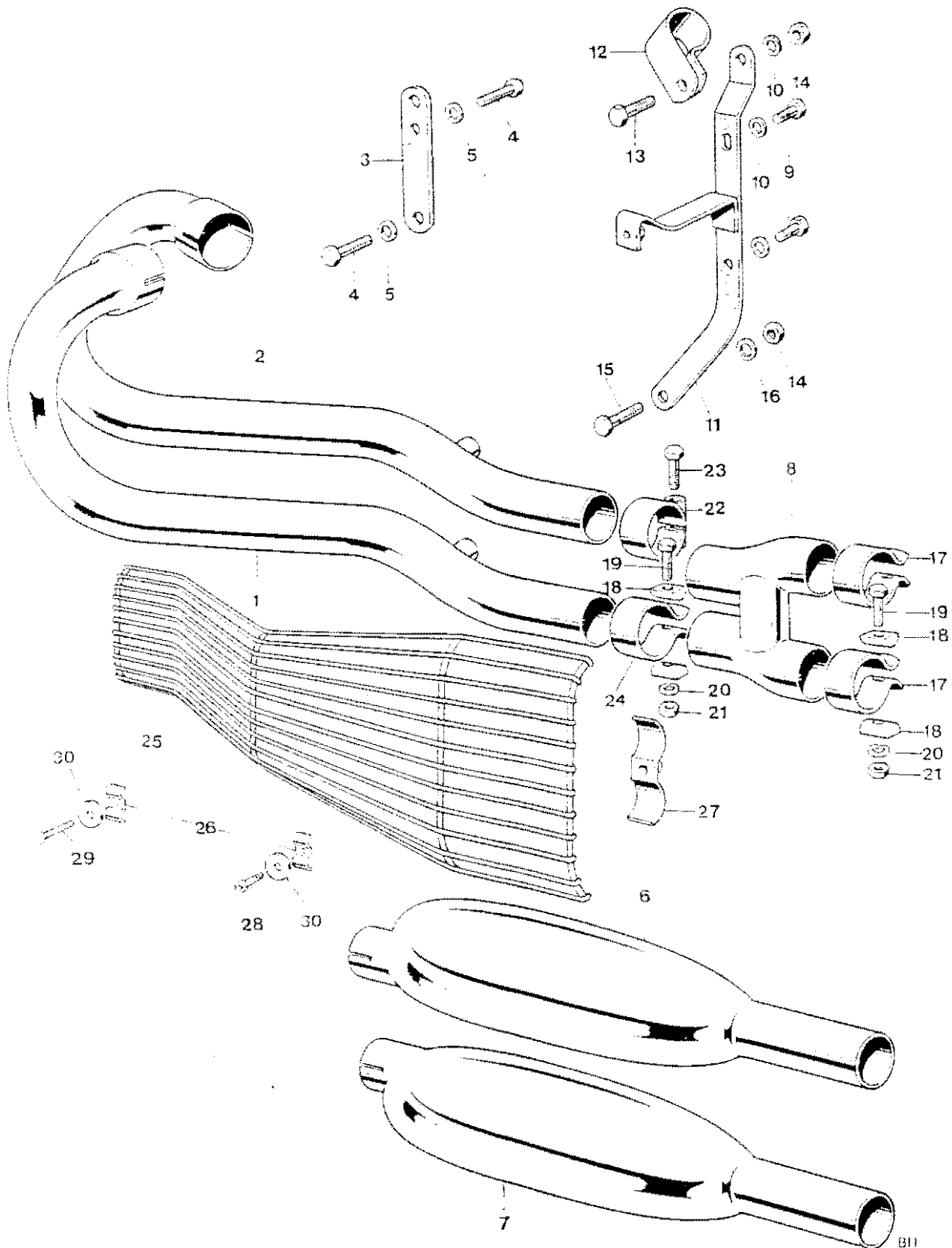

Fig. 16. EXHAUST PIPES AND MUFFLERS (TR6C)

Ref. No.	Part No.	DESCRIPTION	QUANTITY	REMARKS
----------	----------	-------------	----------	---------

**EXHAUST PIPES AND MUFFLERS TR6C**

1	E10024	Exhaust pipe D.S. lower	1	
2	E10022	Exhaust pipe T.S. upper	1	
3	E6978	Exhaust pipe stay	1	
4	14-0113	$\frac{3}{8}$ in. bolt	3	
5	S26-3	Spring washer	3	
6	E9669	Muffler, upper	1	
7	E9670	Muffler, lower	1	
8	E9673	Connector	1	
9	F929	Bolt	2	
10	S26-3	Spring washer	3	
11	E9692	Silencer bracket	1	
12	F7549	Clip	1	
13	14-0114	Bolt (for clip)	1	
14	14-0302	Nut (for clip)	2	
15	14-0115	Bolt hanger to frame	4	
16	S26-3	Spring washer	4	
17	E2271	Clip	2	
18	E3768	"D" washer	6	
19	14-0219	Bolt washer	3	
20	S26-3	Spring washer	3	
21	S1908	Nut	3	
22	E7299	Clip	1	
23	14-0116	Bolt	1	
24	E5874	Clip	1	
25	E9680	Leg guard	1	
26	E9688	Clip	2	
27	E9696	Bracket	1	
28	S1954	Screw (short)	1	
29	S1953	Screw (long) $1\frac{3}{4}$ in. U.H.	1	
30	E9857	Washer	2	

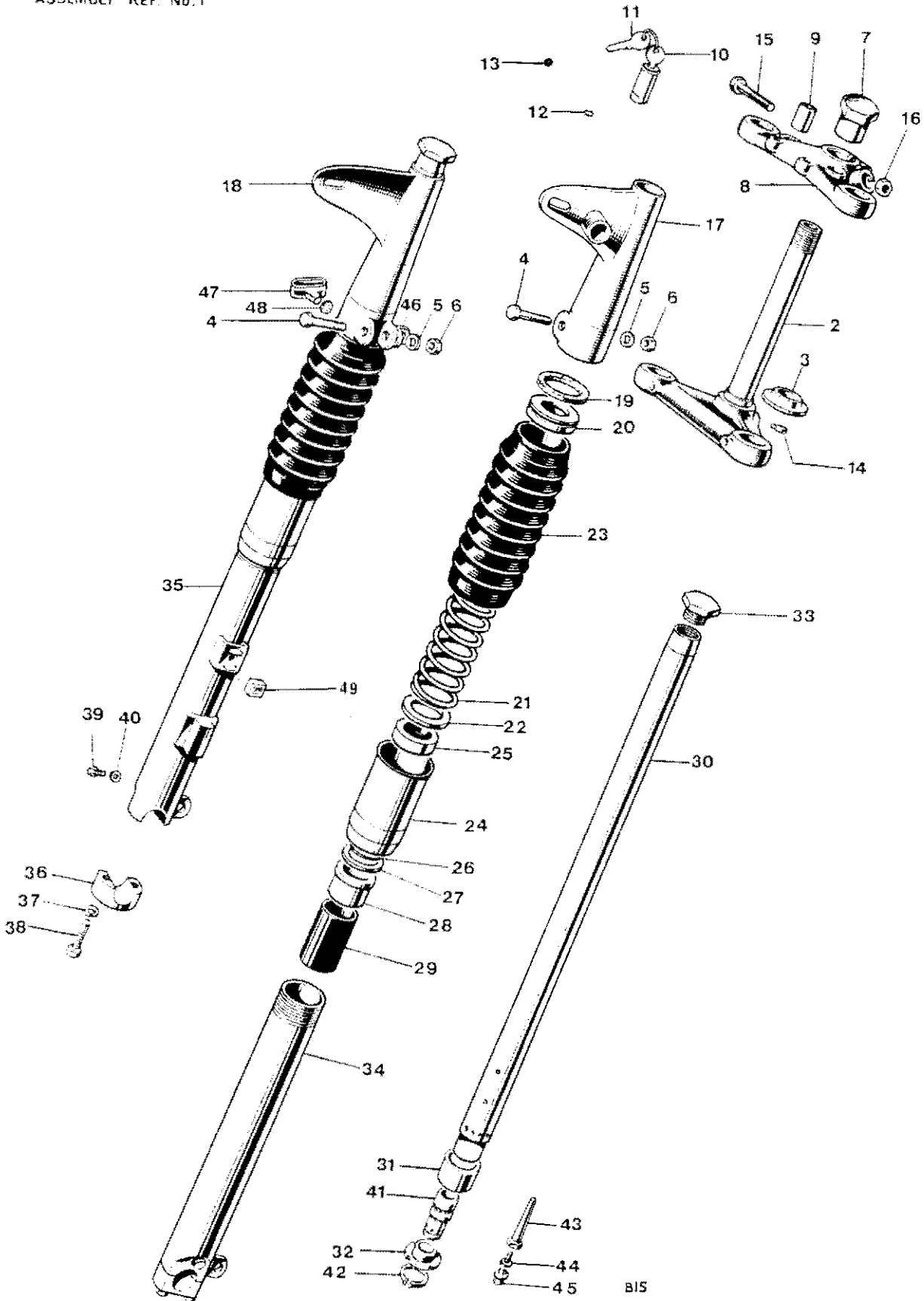

Fig. 16. TELESCOPIC FRONT FORK



Ref. No.	Part No.	DESCRIPTION	QUANTITY	REMARKS
<b>TELESCOPIC FRONT FORK TR6R, T120R</b>				
1	H3907	FORK ASSEMBLY ... ..	1	TR6R
1	H3909	FORK ASSEMBLY ... ..	1	T120R
2	H3659	Middle lug and stem ... ..	1	TR6R
2	H2288	Middle lug and stem ... ..	1	T120R
3	H439	Bottom cone ... ..	1	
4	H2290	Pinch bolt (2 $\frac{1}{4}$ in. U.H.) ... ..	2	
5	S25-2	Plain washer ... ..	2	
6	14-1303	Cleveloc nut ... ..	2	
7	H2263	Fork stem sleeve nut (blind) ... ..	1	
8	H3667	Top lug ... ..	1	
9	H1527	Bonded bush ... ..	2	
10	F6738	Lock c/w 2 keys ... ..	1	
11	D623	Key (state serial number) ... ..	1	Key Nos. run from EJR1 to EJR50
12	S578	Grub screw ... ..	1	
13	H2266	Sealing washer ... ..	1	
14	H2107	Locating pin ... ..	1	
15	S684	Pinch bolt (1 $\frac{1}{8}$ in. U.H.) ... ..	1	
16	S685	Seated nut ... ..	1	
17	H2161	Left top cover ... ..	1	
18	H2162	Right top cover ... ..	1	
19	F4047	Cork washer ... ..	2	
20	H1657	Spring abutment ... ..	2	
21	H1891	Solo main spring (Yellow/Blue) ... ..	2	
21	H1892	Extra strong main spring (Yellow/Green) ... ..	Available	
22	H1656	Plain washer ... ..	2	
23	H3635	Telescopic gaiter ... ..	2	
24	H3633	DUST EXCLUDER SLEEVE NUT ... ..	2	
25	H1500	Oil seal ... ..	2	
26	H2119	"O" ring ... ..	2	
27	H431	Plain washer ... ..	2	
28	H441	Top bearing ... ..	2	
29	H1896	Damping sleeve ... ..	2	
30	H3904	Stanchion ... ..	2	
31	H443	Lower bearing ... ..	2	
32	H2091	Bearing nut ... ..	2	
33	H2245	Cap nut ... ..	2	
34	H3921	LEFT BOTTOM MEMBER c/w CAP ... ..	1	
35	H3922	RIGHT BOTTOM MEMBER c/w CAP ... ..	1	
36	H1844	Spindle cap ... ..	2	
37	S26-3	Spring washer ... ..	4	
38	14-0218	Cap bolt (1 $\frac{7}{8}$ in. U.H.) ... ..	4	
39	H3894	Drain plug ... ..	2	
40	H3893	Fibre washer ... ..	2	
41	H2154	Shuttle valve ... ..	2	
42	H2127	Circlip ... ..	2	
43	H2090	Restrictor ... ..	2	
44	H1062	Aluminium washer ... ..	2	
45	H2126	Flanged bolt ... ..	2	
46	H3682	Brake cable bracket ... ..	1	
47	H2270	Cable retainer ... ..	1	
48	F8245	Starlock washer ... ..	1	
49	H3926	Square nut ... ..	2	

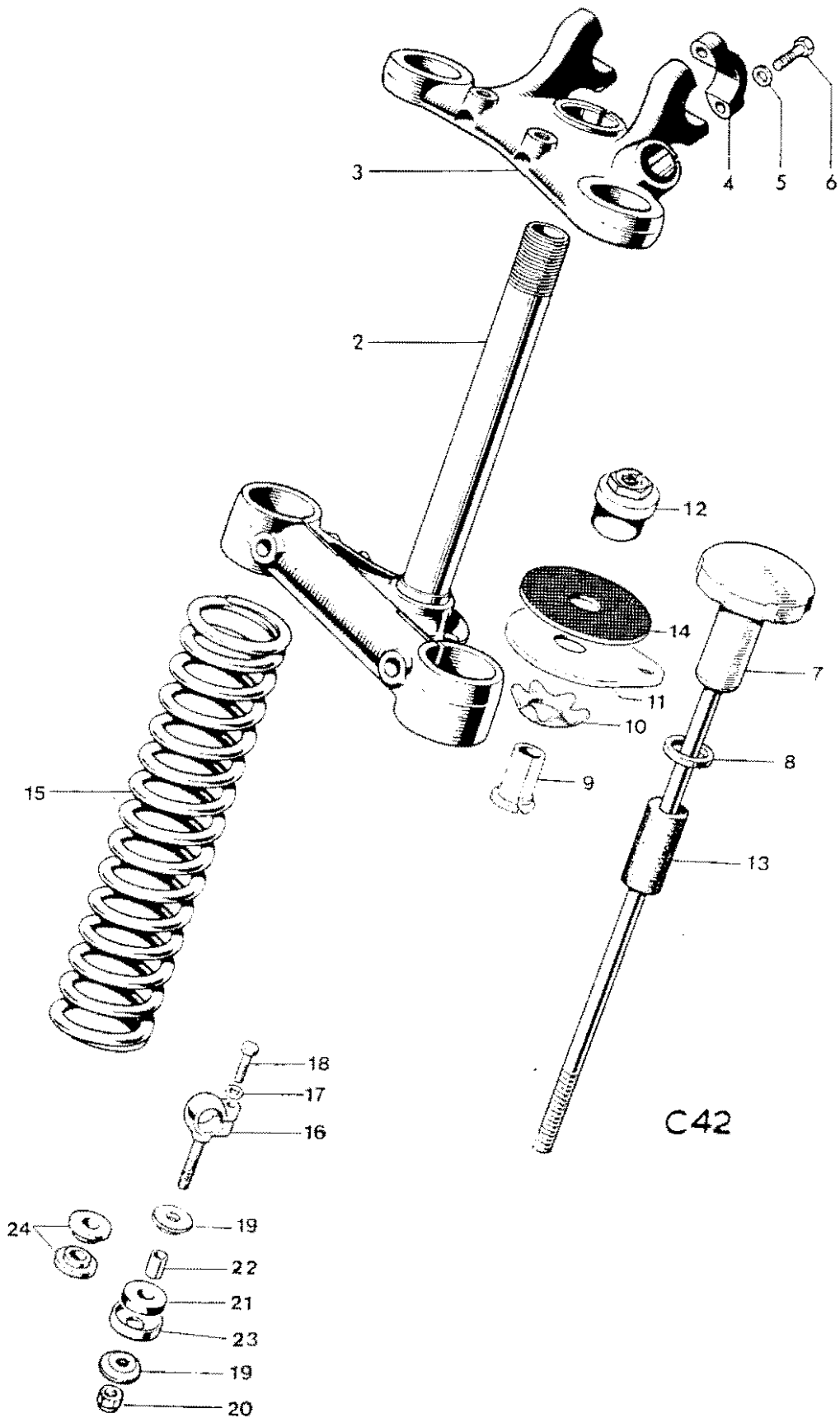

Fig. 18. TR6C FORK PARTS AND STEERING DAMPER

Ref. No.	Part No.	DESCRIPTION	QUANTITY	REMARKS
----------	----------	-------------	----------	---------

**TR6C FORK PARTS AND STEERING DAMPER**

1	H3908	FORK ASSEMBLY	1	
2	H2288	Middle lug and stem	1	
3	H3662	Top lug	1	
4	H722	Cap	2	
5	S25-3	Plain washer	4	
6	S589	Bolt (1 1/8 in. U.H.)	4	
7	H1142	Steering damper rod c/w knob	1	
8	H565	Plain washer	1	
9	H408	Adjuster sleeve	1	
10	H95	Spring plate	1	
11	H1797	Anchor plate	1	
12	H2108	Fork stem sleeve nut	1	
13	H1618	Rubber sleeve	1	
14	H435	Friction disc	1	
15	H1892	Main spring (yellow-green)	2	

All other parts are as listed on Page 47

**HANDLEBAR MOUNTINGS**

16	H2291	Handlebar eyebolt	2	} TR6R, T120R
17	F1335	Plain washer	2	
18	S589	Bolt (1 1/8 in. U.H.)	2	
19	H1529	Hemispherical washer	4	
20	14-1903	Self-locking nut	2	
21	H1580	Steady rubber	2	
22	H1581	Distance piece	2	
23	H2221	Cup	2	
24	H1616	Solid bush (for handlebar-mounted windscreen)	as required	

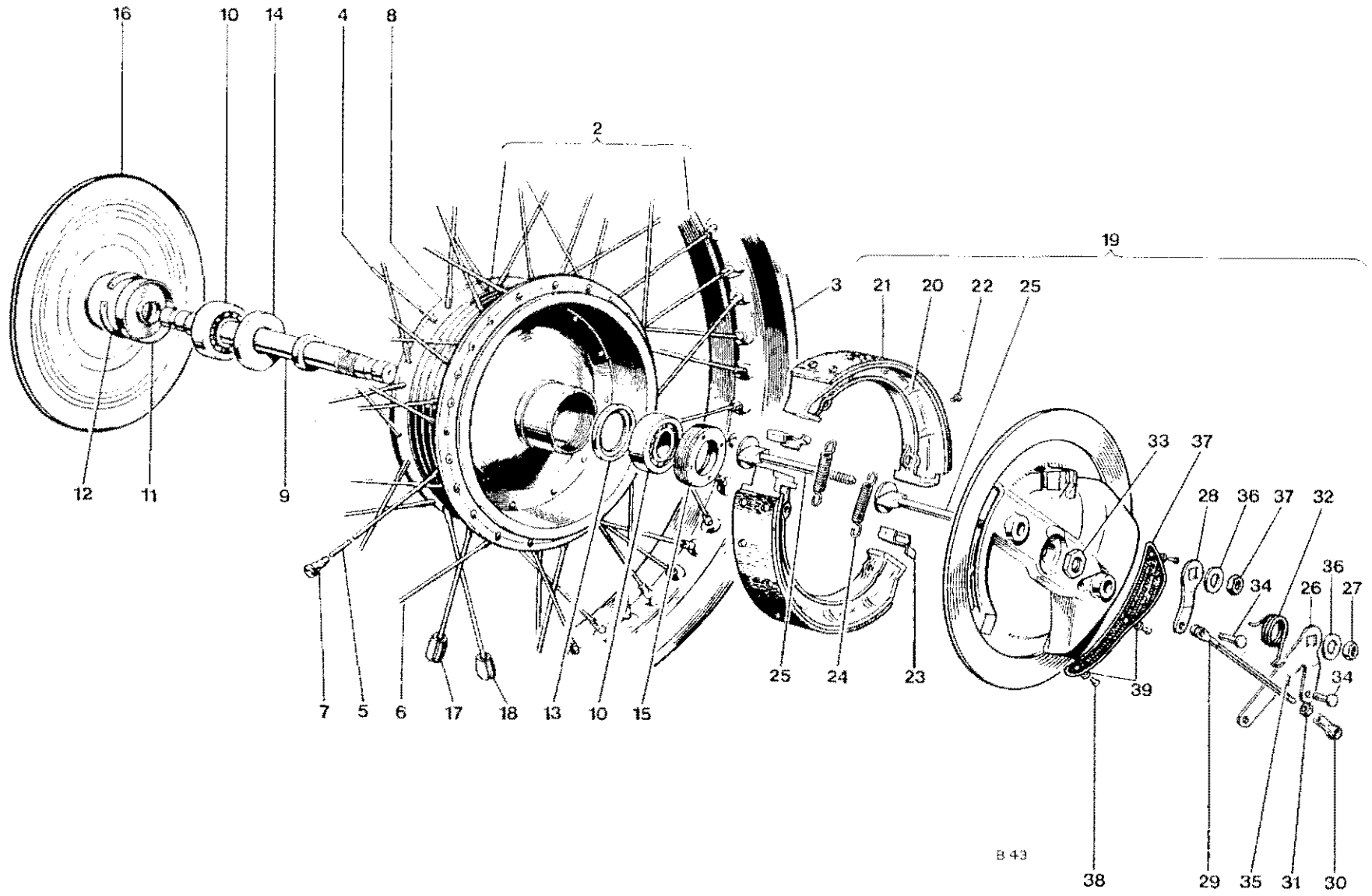

Fig. 19. FRONT WHEEL

Ref. No.	Part No.	DESCRIPTION	QUANTITY	REMARKS
<b>FRONT WHEEL</b>				
1	W3458	FRONT WHEEL COMPLETE	1	
2	W1721	RIM, SPOKES AND HUB ASSEMBLY	1	
3	W1230	Front wheel rim (WM2-19)	1	
4	W1328	Spoke (8/10G x 5 $\frac{5}{8}$ in. straight)	20	
5	W1708	Spoke (8/10G x 4 $\frac{3}{4}$ in. 78°)	10	
6	W1709	Spoke (8/10G x 4 $\frac{7}{8}$ in. 100°)	10	
7	S79-2	Spoke nipple	40	
8	W1722	Hub and brake drum	1	
9	W3582	Wheel spindle	1	
10	W653	Bearing	2	
11	W1237	Dust cover	1	
12	T280	Circlip	1	
13	W3337	Bearing support ring	1	
14	W1481	Grease retainer	1	
15	W582	Retaining ring	1	
16	W3460	Cover plate	1	
17	W1197	Balance weight, $\frac{1}{2}$ oz.	as required	
18	W1198	Balance weight, 1 oz.	as required	
19	W3461	BRAKE ANCHOR PLATE ASSEMBLY	1	
20	W1996	BRAKE SHOE C/W LINING	2	
21	Reference only	Brake lining	1	} Each shoe
22	Reference only	Brass rivet	8	
23	W2026	Thrust pad	2	
24	W135	Shoe return spring	2	
25	W2001	Brake cam	1	
26	W3453	Brake cam lever (front)	1	
27	14-0303	Nut	2	
28	W3454	Brake cam lever (rear)	1	
29	W2003	Rod assembly	1	
30	W2005	Fork end, threaded	1	
31	14-0401	Locknut	1	
32	W3522	Lever return spring	1	
33	S1995	Anchor plate nut	1	
34	WF32	Pivot pin	2	
35	—	Split pin ( $\frac{1}{16}$ in. x $\frac{3}{8}$ in. long)	Reference only	
36	S25-6	Plain washer	2	
37	W1991	Anchor plate gauze (for air scoop)	1	
38	S1998	Taptite screw	3	
39	E2351	Washer for taptite screws	3	

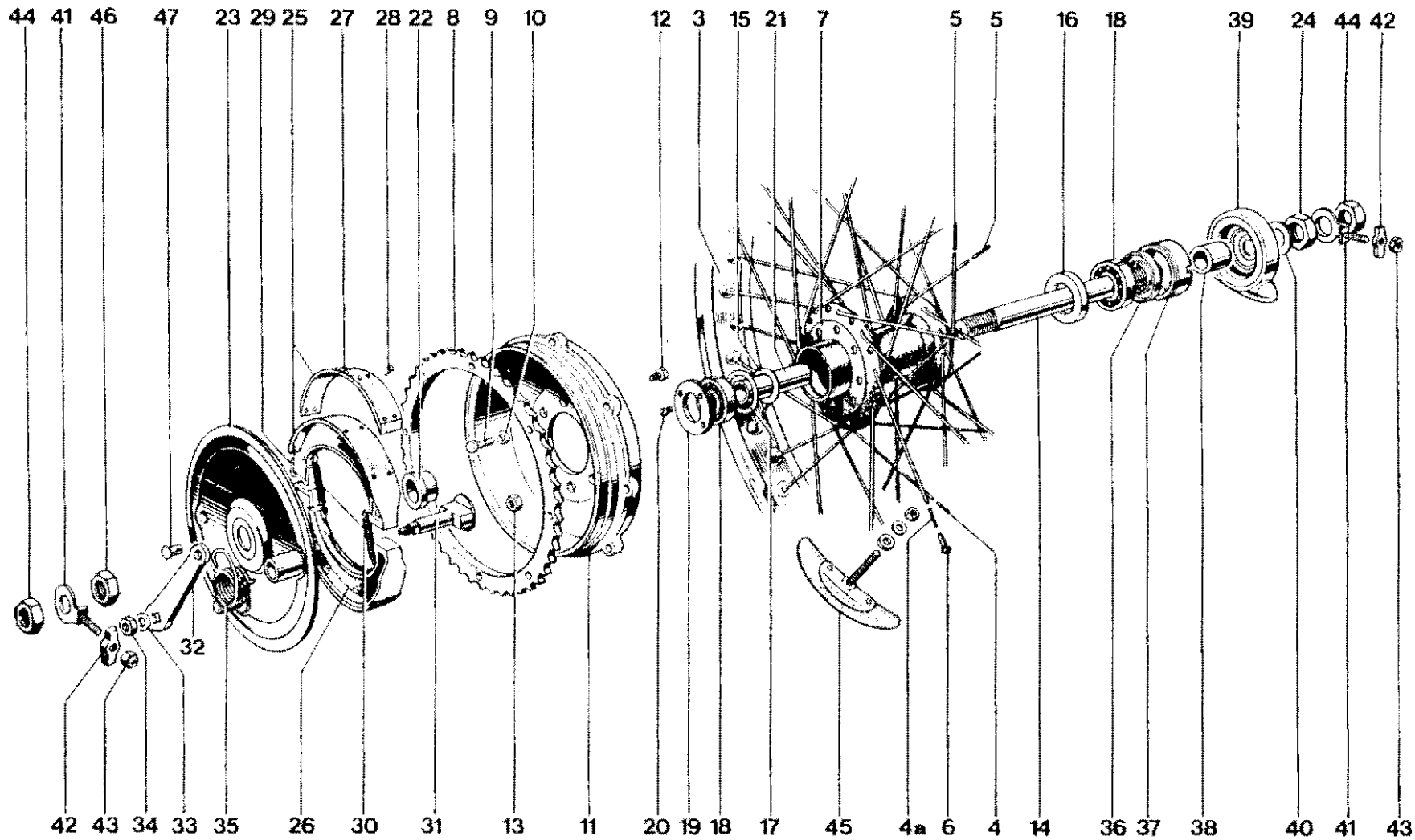

Fig. 20. REAR WHEEL

B10

Ref. No.	Part No.	DESCRIPTION	QUANTITY	REMARKS
<b>REAR WHEEL</b>				
1	W3604	REAR WHEEL COMPLETE ... ..	1	
2	W3610	RIM, SPOKES AND HUB ASSEMBLY ... ..	1	
3	W1007	Rear wheel rim WM3-18 ... ..	1	
4	W1107	Spoke (8/10G x 7 $\frac{9}{16}$ in. 90°) ... ..	10	
4A	W3402	Spoke (8/10G x 7 $\frac{9}{16}$ in. 110°) ... ..	10	
5	W1108	Spoke (8/10G x 7 $\frac{7}{8}$ in. 90°) ... ..	20	
6	S79-2	Spoke nipple ... ..	40	
7	W3586	Hub ... ..	1	
8	W1499	Sprocket, 46T ... ..	1	
9	S2010	Bolt ( $\frac{1}{8}$ in. U.H.) ... ..	8	
10	E1612	Serrated washer ... ..	8	
11	W3585	Brake drum ... ..	1	
12	S2011	Bolt ( $\frac{1}{8}$ in. U.H.) ... ..	8	
13	14-1202	Self locking nut ... ..	8	
14	W3589	Wheel spindle ... ..	1	
15	W1474	Grease retainer (brake side) ... ..	1	
16	W1654	Grease retainer ... ..	1	
17	W1022	Backing ring ... ..	1	
18	W653	Bearing ... ..	2	
19	W3587	RETAINING RING ... ..	1	
20	W1710	Locking screw ( $\frac{5}{16}$ in. U.H.) ... ..	1	
21	W1278	Distance tube ... ..	1	
22	W1024	Distance piece ... ..	1	
23	W3590	Brake anchor plate ... ..	1	
24	S2013	Nut ... ..	1	
25	W1406	LEADING BRAKE SHOE C,W LINING ... ..	1	
26	W1407	TRAILING BRAKE SHOE C,W LINING ... ..	1	
27	Reference only	Brake lining ... ..	2	} Not supplied separately
28	Reference only	Brass rivet ... ..	16	
29	W1415	Thrust pad ... ..	2	
30	W135	Shoe return spring ... ..	2	
31	W3592	Brake cam ... ..	1	
32	W2015	Brake cam lever ... ..	1	
33	W2027	Plain washer ... ..	1	
34	14-0403	Nut ... ..	1	
35	W1090	Lever return spring ... ..	1	
36	W1635	Grease retainer ... ..	1	
37	W3588	Speedometer adaptor ... ..	1	
38	W1477	Distance piece ... ..	1	
39	D637	Speedometer gearbox ... ..	1	
40	W1280	Plain washer ... ..	1	
41	W2089	Chain adjuster ... ..	2	
42	W1015	Adjuster end plate ... ..	2	
43	14-1902	Self-locking nut ... ..	2	
44	S585	Spindle nut ... ..	2	
45	W113	Tire security bolt ... ..	2	
46	W2014	Nut inner D.S. ... ..	1	
47	W1467	Pivot pin ... ..	1	

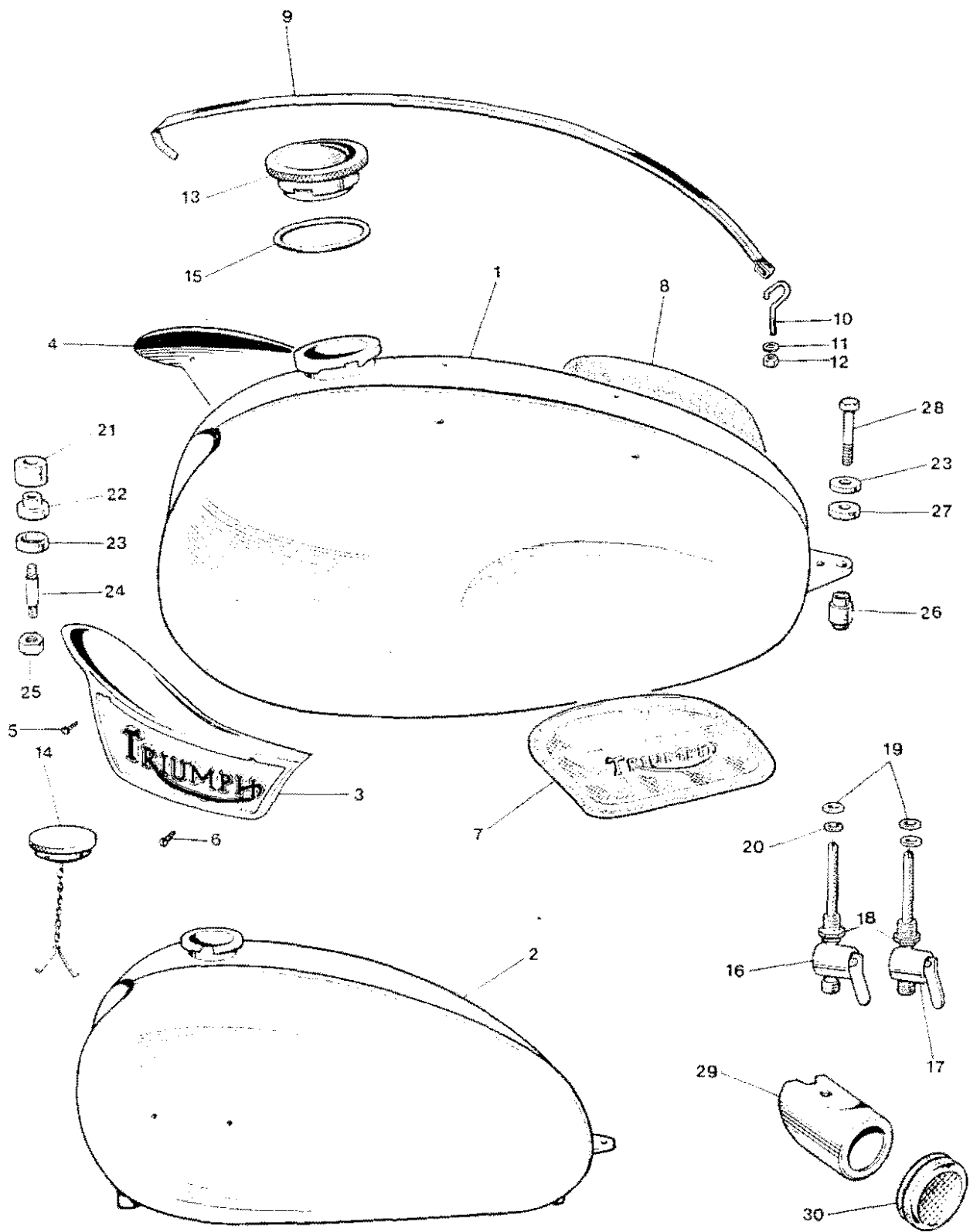

Fig. 21. GAS TANKS



Ref. No.	Part No.	DESCRIPTION	QUANTITY	REMARKS
<b>GAS TANKS</b>				
1	F11802	Gas tank (3½ gallons) ... ..	1	TR6R
2	F11801	Gas tank (2½ gallons) ... ..	1	TR6C
2	F11798	Gas tank (2½ gallons) ... ..	1	T120R
3	F11340	Styling unit (left) ... ..	1	
4	F11341	Styling unit (right) ... ..	1	
5	F11339	Styling unit screw (front) ... ..	2	
6	F7888	Styling unit screw (rear) ... ..	2	
7	F8192	Left knee grip ... ..	1	
8	F8193	Right knee grip ... ..	1	
9	F10031	Centre styling strip ... ..	1	
10	F10008	Hook screw ... ..	1	
11	F4019	Serrated washer ... ..	1	
12	H919	Nut ... ..	1	
13	F3220	FILLER CAP ... ..	1	
14	F3219	FILLER CAP c/w CHAIN ... ..	1	TR6C
15	F4048	Joint washer ... ..	1	
16	F4971	PETROL TAP (LEFT) ... ..	1	
17	F4972	PETROL TAP WITH RESERVE TUBE ... ..	1	
18	F10006	Petrol tap nut ... ..	2	Supplied with tap
19	E7351	Petrol tap seal ... ..	2	
20	F10002	Steel washer ... ..	2	
21	F5228	Rubber washer ... ..	2	
22	F5229	Spigot rubber ... ..	2	
23	F3814	Cup ... ..	3	
24	S1883	Shouldered stud ... ..	2	
25	14-1302	Nut ... ..	2	
26	F5336	Double spigot rubber ... ..	1	
27	F967	Rubber washer ... ..	1	
28	F7388	Bolt (1½ in. U.H.) ... ..	1	
29	F8194	Reflector bracket ... ..	2	
30	57161	Reflector, Amber (D691) ... ..	2	
Not illus.	D2026	Decal—Bonneville ... ..	1	
Not illus.	D2027	Decal—Trophy 650 ... ..	1	TR6C
Not illus.	D678	Decal—Trophy Sports ... ..	1	TR6R
Not illus.	A61	Decal—Made in England ... ..	1	

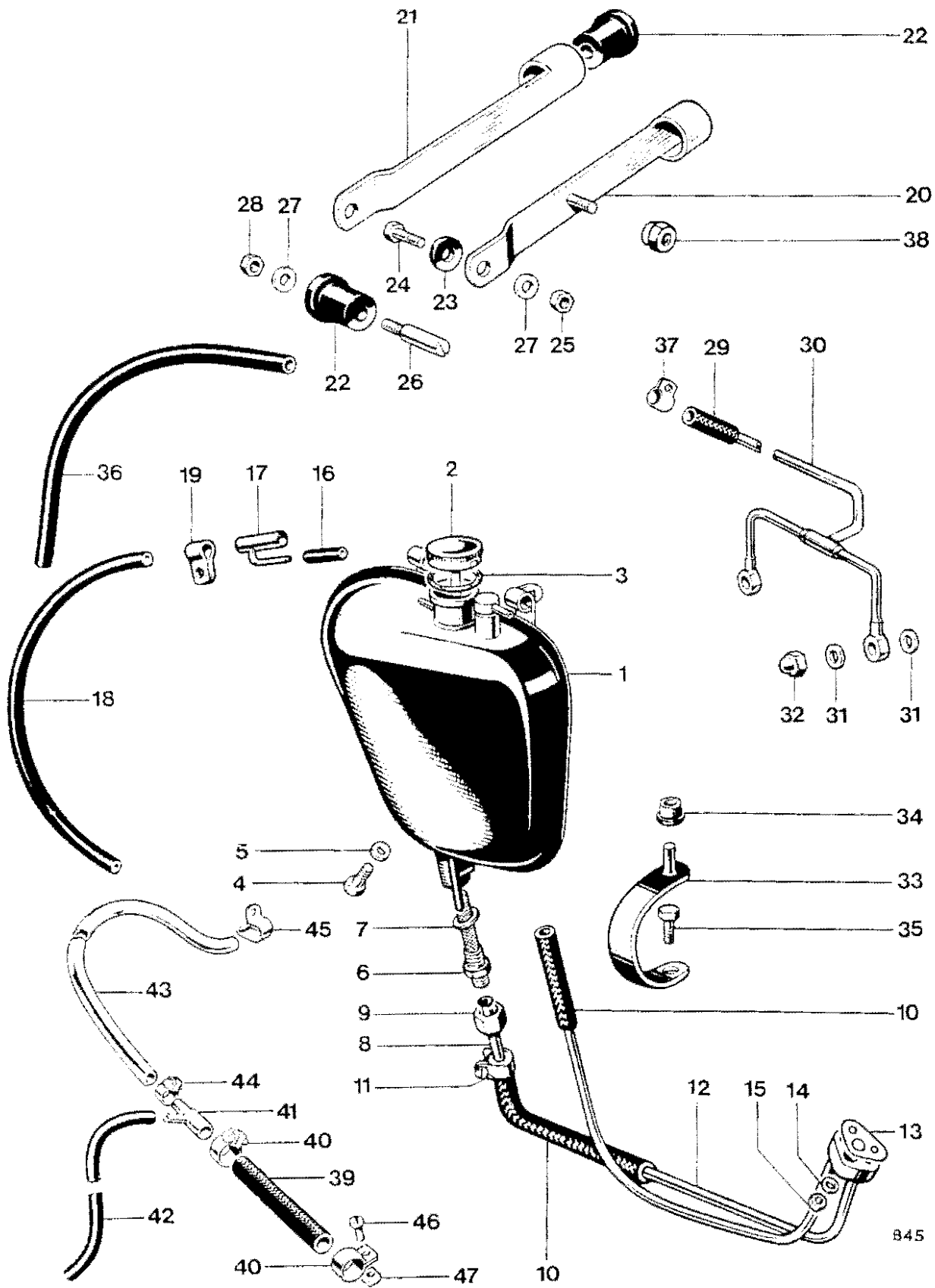

Fig. 22. OIL TANK

**OIL TANK, OIL PIPES AND BREATHER PIPES**

1	F11577	Oil tank ... ..	1	
2	F9659	FILLER CAP ... ..	1	
3	F4047	Joint washer ... ..	1	
4	F5343	Drain plug ... ..	1	
5	99-0048	Fibre washer ... ..	1	
6	F3179	Oil tank filter ... ..	1	
7	F1713	Fibre washer ... ..	1	
8	F3655	Upper feed pipe ... ..	1	
9	F3182	Union nut ... ..	1	
10	E4594	Flexible connector ... ..	2	
11	E6848	Clip ... ..	4	
12	E6930	Oil pipes and junction block ... ..	1	
13	E3763	Joint washer ... ..	1	
14	E3446	Plain washer ... ..	1	
15	E1310	Nut ... ..	1	
16	E6356	Vent pipe ... ..	1	
17	E5370	"T" piece ... ..	1	
18	F7353	Extension pipe ... ..	1	
19	F3098	Clip ... ..	2	
20	F9255	Front strap ... ..	1	
21	F8028	Rear Strap ... ..	1	
22	F6673	Spigot rubber ... ..	4	
23	F6968	Rubber washer ... ..	2	
24	14-0103	Bolt ( $\frac{3}{8}$ in. U.H.) ... ..	2	
25	14-0701	Self locking nut ... ..	2	
26	F7510	Screwed peg ... ..	2	
27	S25-13	Plain washer ... ..	4	
28	14-0301	Nut ... ..	2	
29	E6353	Rubber connector ... ..	1	
30	E6349	Rocker oil feed pipe ... ..	1	
31	E1335	Copper washer ... ..	4	
32	E1435	Domed nut ... ..	2	
33	F6147	Bracket ... ..	1	
34	F6039	Grommet ... ..	1	
35	S1822	Bolt ( $\frac{1}{2}$ in. U.H.) ... ..	1	
36	F7352	Flexible pipe ... ..	1	
37	E6849	Clip ... ..	1	
38	F8034	Sleeve nut ... ..	1	
Not illus.	D1918	Grouped transfer "Drain and refill" etc. ... ..	1	
39	E11149	Breather vent pipe ... ..	1	
40	D2253	Clip ... ..	2	
41	F11610	"T" piece connector ... ..	1	
42	F11613	Vent pipe, froch tower ... ..	1	
43	F11614	Breather tube, rear guard ... ..	1	
44	D2252	Clip, tube to "T" piece ... ..	1	
45	F11615	Clip, tube to rear guard ... ..	4	
46	H3894	2 B.A. screw, clip at rear guard ... ..	4	
47	F4717	2 B.A. nut, clip at rear guard ... ..	4	

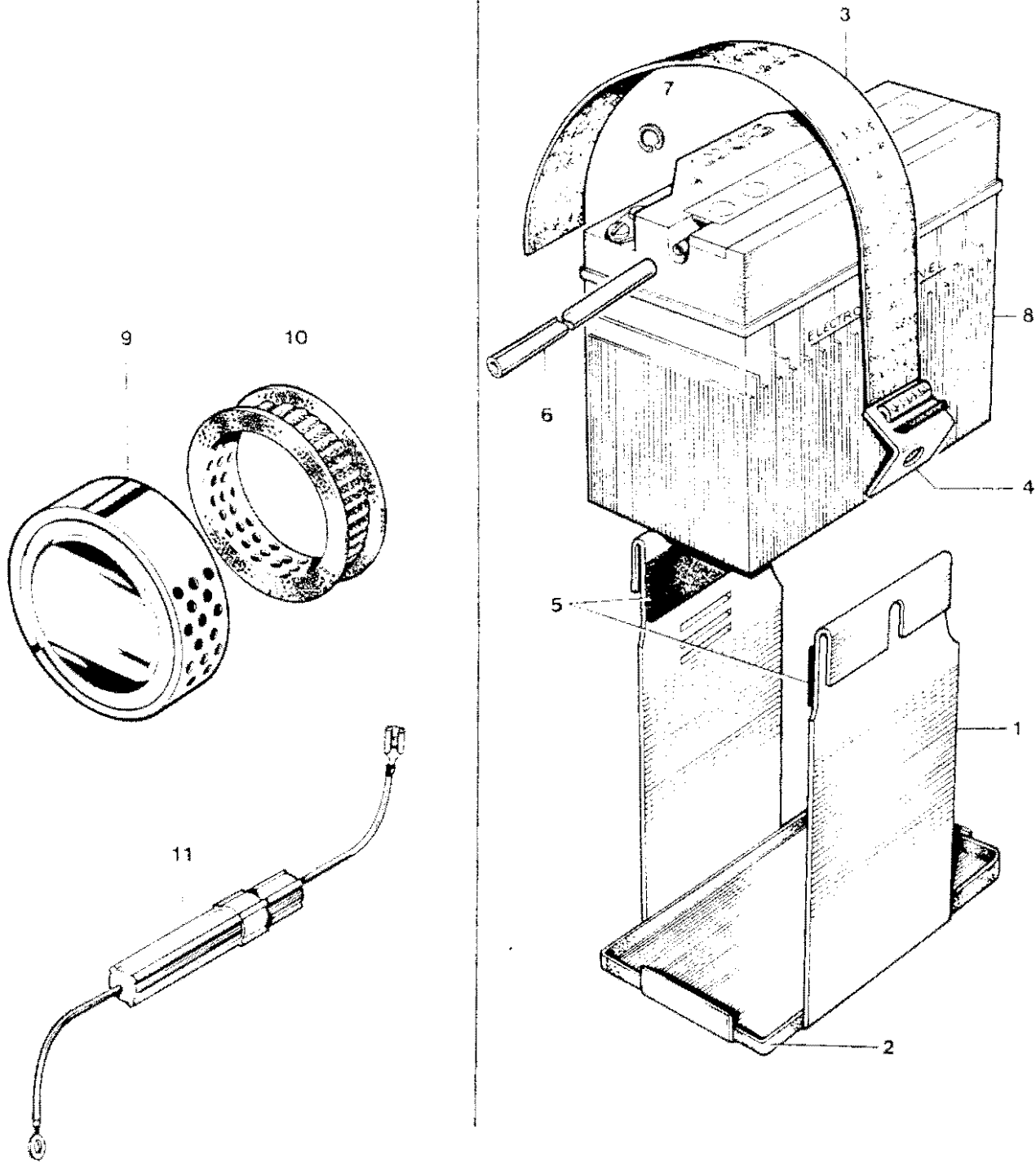

Fig. 23. BATTERY CARRIER AND AIR FILTERS

Ref. No.	Part No.	DESCRIPTION	QUANTITY	REMARKS
----------	----------	-------------	----------	---------

**BATTERY CARRIER AND AIR FILTERS**

1	F8024	Battery carrier ... ..	1	
2	F8091	Battery carrier rubber tray ... ..	1	
3	F8033	Battery carrier strap ... ..	1	
4	F8032	Battery strap anchorage ... ..	1	
5	F8031	Battery carrier rubber strip ... ..	1	
6	F7431	Vent pipe ... ..	1	
7	F7892	Circlip, vent pipe ... ..	1	
8	PUZ5A	Battery (99-0719) 54027029 ... ..	1	
9	F11537	AIR CLEANER ... ..	1	} TR6R, TR6C
10	F6866	Air cleaner element (filter cloth & gauze) ... ..	1	
9	F11536	AIR CLEANER ... ..	2	} T120R
10	F6866	Air cleaner element (filter cloth & gauze) ... ..	2	
11	54938986	Fuse assembly ... ..		Reference only
Not illus.	F4810	Clip for air cleaner cover ... ..	1	

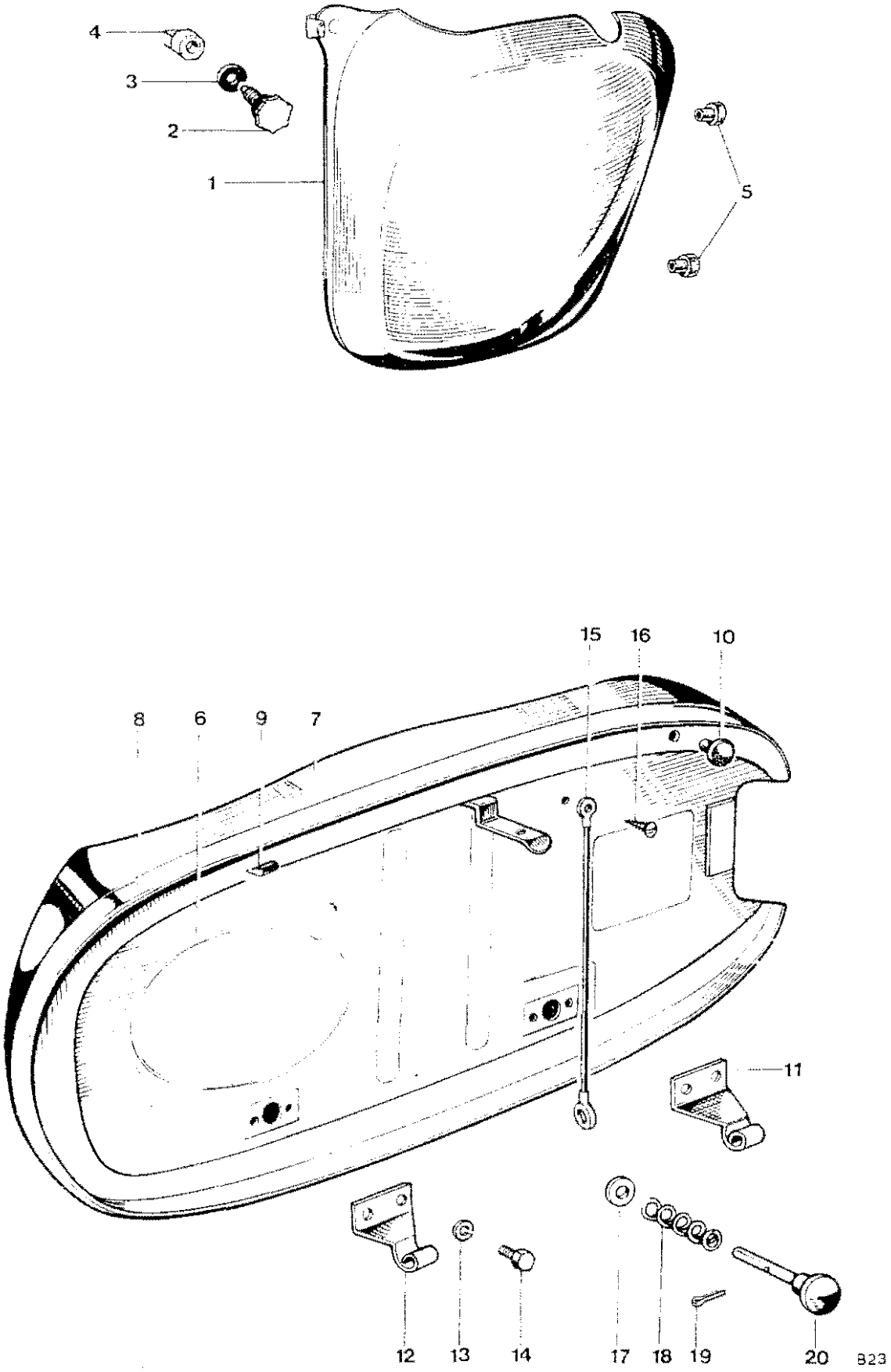

Fig. 24. PANEL AND TWINSEAT

Ref. No.	Part No.	DESCRIPTION	QUANTITY	REMARKS
<b>PANEL AND TWINSEAT</b>				
1	F8042	Side panel and toolbox	1	
Not illus.	D2102	Decal—TIGER 650	1	TR6R
Not illus.	D2104	Decal—TROPHY 650	1	TR6C
Not illus.	D2103	Decal—BONNEVILLE	1	T120R
2	F11357	Panel knob	1	
3	F11377	Washer	1	
4	F10222	Panel nut	1	
5	F6673	Panel grommet	2	
6	F11573	TWINSEAT	1	
7	F9715	Twinseat cover	1	
Not illus.	A52	Transfer, Positive Earth	1	
8	D696	Trim strip	1	
9	D697	Trim strip sprag	4	
10	F4898	Rubber buffer, front	2	
10	F7835	Rubber buffer, rear	2	
11	F8026	Hinge—front	1	
12	F7862	Hinge—rear	1	
13	S26-2	Spring washer	4	
14	14-0101	Bolt ( $\frac{1}{2}$ in. U.H.)	4	
15	D374	Check wire	1	
16	D2381	Self tapping screw	1	
17	E1719A	Washer	1	
18	F4228	Spring	1	
19	—	Split pin ( $\frac{3}{32}$ in. x $\frac{1}{2}$ in.)		Reference only
20	F7560	Seat catch plunger	1	

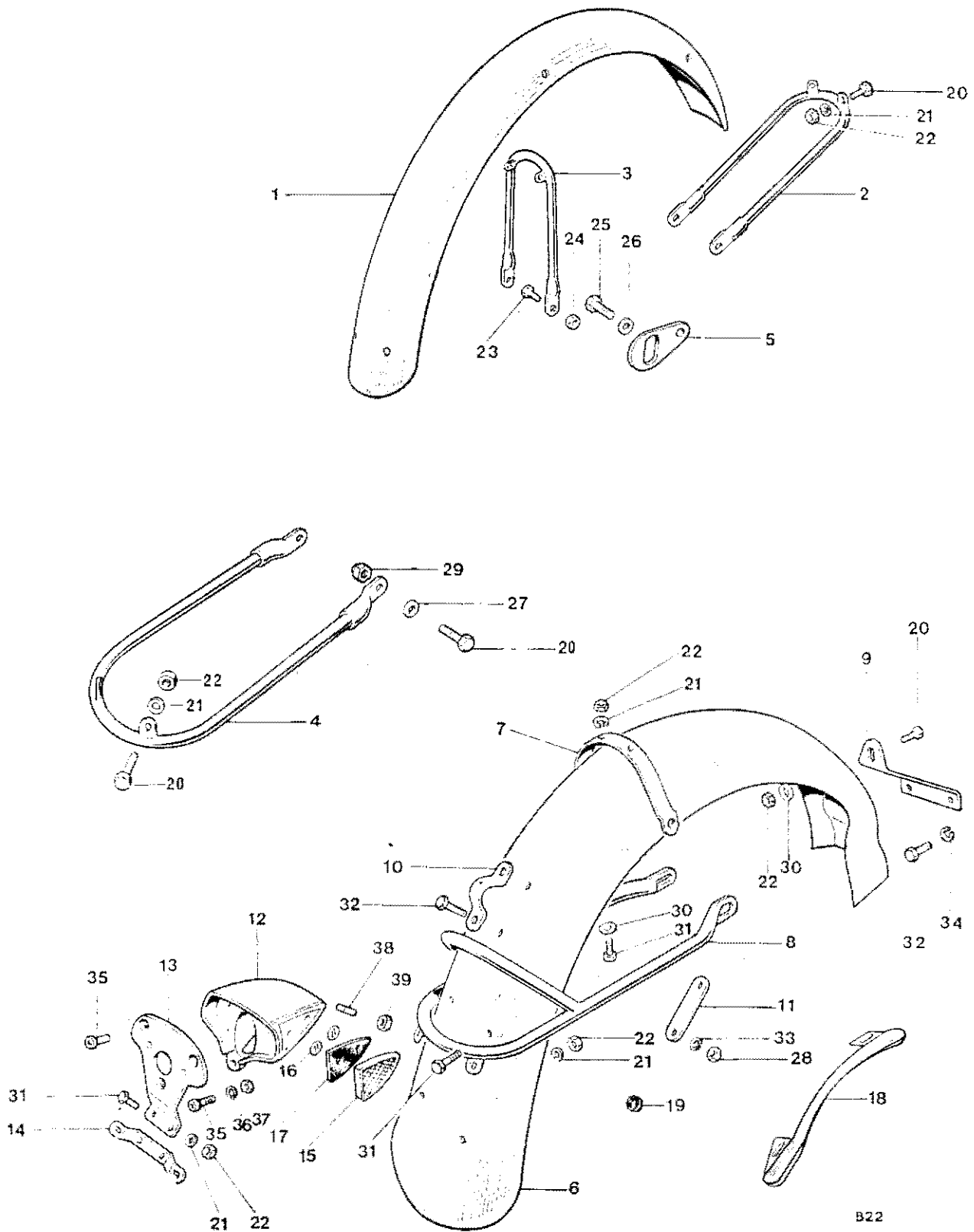

Fig. 25. FENDERS



Ref. No.	Part No.	DESCRIPTION	QUANTITY	REMARKS
<b>FENDERS</b>				
1	H3882	Front fender (painted) ... ..	1	T120R, TR6R
1	H3884	Front fender (stainless steel) ... ..	1	TR6C
2	H1681	Front stay ... ..	1	TR6C
2	H3663	Front stay ... ..	1	TR6R, T120R
3	H1683	Centre stay ... ..	1	TR6C
3	H3664	Centre stay ... ..	1	TR6R, T120R
4	H3886	Bottom stay ... ..	1	TR6R, T120R
4	H3885	Bottom stay ... ..	1	TR6C
5	H1685	Bracket ... ..	2	
6	*F11618	Rear fender ... ..	1	TR6C
6	*F11619	Rear fender ... ..	1	TR6R, T120R
7	F6915	Bridge ... ..	1	
8	F11571	Lifting handle ... ..	1	
9	F6851	Bracket ... ..	1	
10	F5994	Clip ... ..	1	
11	F6031	Backing plate ... ..	1	
12	F8139	Tail lamp adaptor ... ..	1	
13	F6849	Tail lamp plate ... ..	1	
14	F6850	Number plate bracket ... ..	1	
15	57111	Reflector red (99-1030) ... ..	2	
16	F8195	Push fix ... ..	4	
17	F8140	Rubber mat ... ..	2	
18	F7826	Wiring protector ... ..	1	
19	199001	Tail lamp lead grommet ... ..		Reference only
20	14-0101	Bolt ( $\frac{7}{16}$ in. U.H.) ... ..	6	
21	S25-1	Plain washer ... ..	13	
22	14-1201	Nut ... ..	14	
23	14-0115	Bolt ( $\frac{5}{16}$ in. U.H.) ... ..	4	
24	14-0402	Nut ... ..	2	
25	S1822	Bolt ( $\frac{1}{2}$ in. U.H.) ... ..	2	
26	F4299	Plain washer ... ..	2	
27	S25-3	Washer ... ..	2	
28	14-0302	Nut ... ..	2	
29	14-0702	Self-locking nut ... ..	2	
30	F6310	Plain washer ... ..	3	
31	14-0102	Bolt ( $\frac{5}{8}$ in. U.H.) ... ..	12	
32	14-0113	Bolt ( $\frac{3}{4}$ in. U.H.) ... ..	4	
33	E2287	Spring washer ... ..	2	
34	S26-3	Spring washer ... ..	2	
35	F4715	Screw ... ..	3	
36	GS299	Washer ... ..	1	
37	F3799	Nut ... ..	1	
38	14-1401	Stud (1 in. O.A.) ... ..	1	
39	F879	Nut ... ..	1	

\* Appropriate colour code suffix must be added when ordering replacement Fenders.

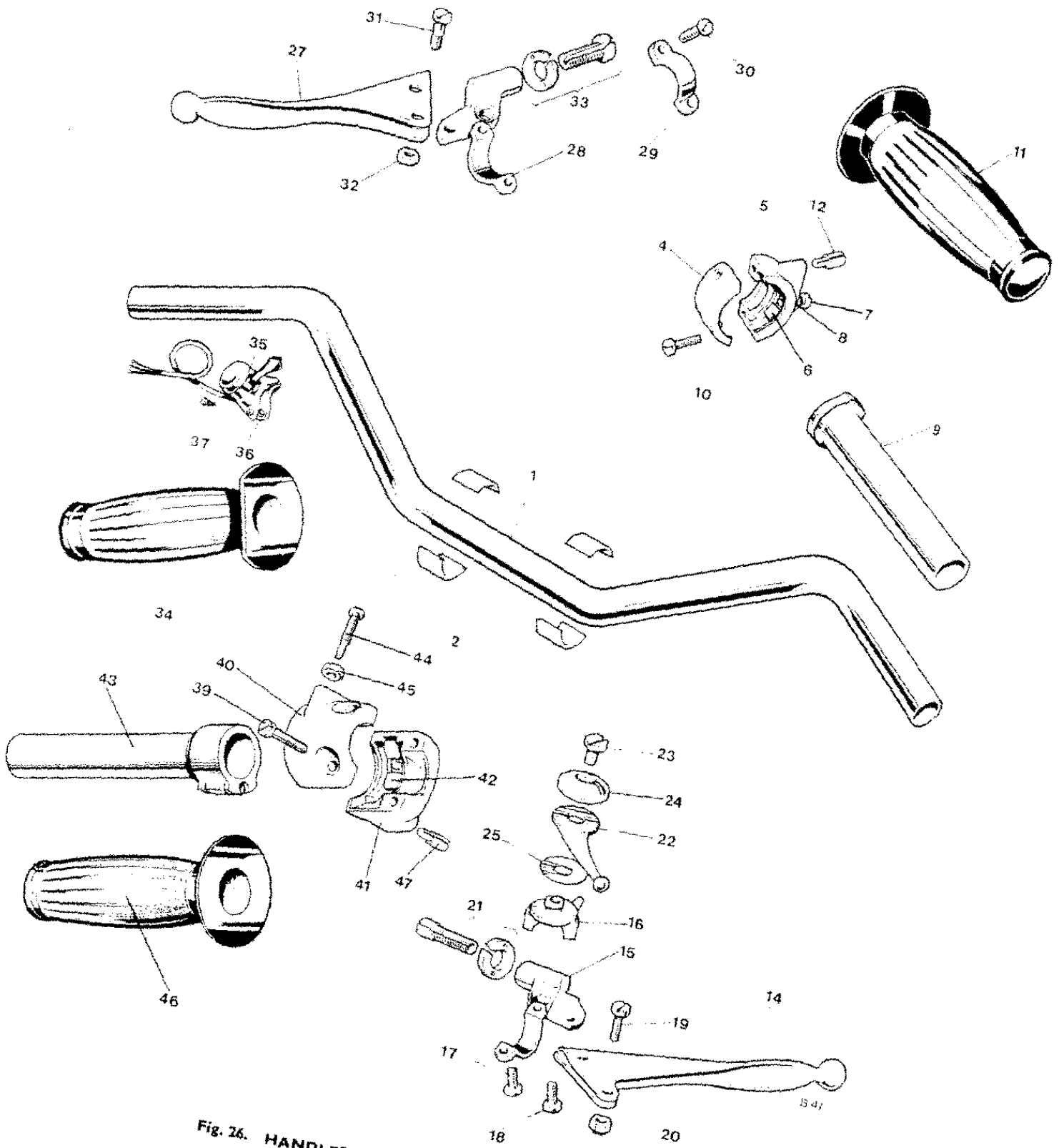

Fig. 26. HANDLEBARS AND CONTROL LEVERS

**HANDLEBARS AND CONTROL LEVERS (SEE ALSO PAGE 67)**

1	H1870	Handlebar	1	TR6R, T120R
2	H1425	Packing piece	4	TR6R, T120R
3	16/364	TWISTGRIP (99-0248)	1	TR6C, TR6R
4	16/328	Body top half (99-0245)	1	
5	16/329	Body bottom half (99-0246)	1	
6	16/008	Friction spring (99-0238)	1	
7	16/009	Friction spring screw (99-0239)	1	
8	16/010	Locknut (99-0240)	1	
9	16/091	Rotor (99-0244)	1	
10	11/013	Screw (99-0225)	2	
11	Reference only	Grip	1	
12	16/011	Cable stop (99-0241)	1	
13	D2241	FRONT BRAKE AND AIR LEVER ASSEMBLY (19/978)	1	
14	18/754	Brake lever (ball end) (99-0262)	1	
15	19/001	Lever bracket (99-1093)	1	
16	12/619	Control body (99-0234)	1	
17	11/014	Screw (99-0226)	1	
18	11/013	Screw (99-0225)	1	
19	18/087	Fulcrum screw (99-0252)	1	
20	18/053	Self locking nut (99-0250)	1	
21	18/1708/1709	Cable adjuster and nut (99-1031)	1	
22	12/556	Lever (99-0228)	1	
23	12/607	Bolt	1	
24	12/606	Cap	1	
25	12/033	Spring washer	1	
26	D2242	CLUTCH LEVER ASSEMBLY 19/952	1	
27	18/752	Clutch lever (ball end) (99-0261)	1	
28	19/002	Clutch lever bracket (99-1094)	1	
29	12/595	Clamp (99-0230)	1	
30	11/014	Screw (99-0226)	2	
31	18/087	Fulcrum screw (99-0252)	1	
32	18/053	Self locking nut (99-0250)	1	
33	18/1708/1709)	Cable adjuster and nut (99-1031)	1	
34	Reference only	Handlebar grip	1	
35	31563	Horn push and dip switch (99-0555)	1	
36	380459	Backing rubber (99-0630)	1	
37	H1994	Self-tapping screw (½ in. U.H.)	2	
38	313/13	TWIN ROTOR TWIST GRIP (99-0347)	1	T120R
39	18/084	Screw (99-0251)	2	
40	313/020	Body, top half (99-0348)	1	
41	313/021	Body, bottom half (99-0349)	1	
42	16/008	Friction spring (99-0238)		Reference only
Not illus.	210/007	Adjuster screw (99-0337)		Reference only
Not illus.	5/077	Nut (99-0224)		Reference only
43	313/004	Rotor (99-0344)	1	
44	210/008	Rotor stop (99-0338)	1	
45	5/077	Nut (99-0224)	1	
46	H2125	Grip	1	
47	16/011	Cable stop (99-0241)	2	

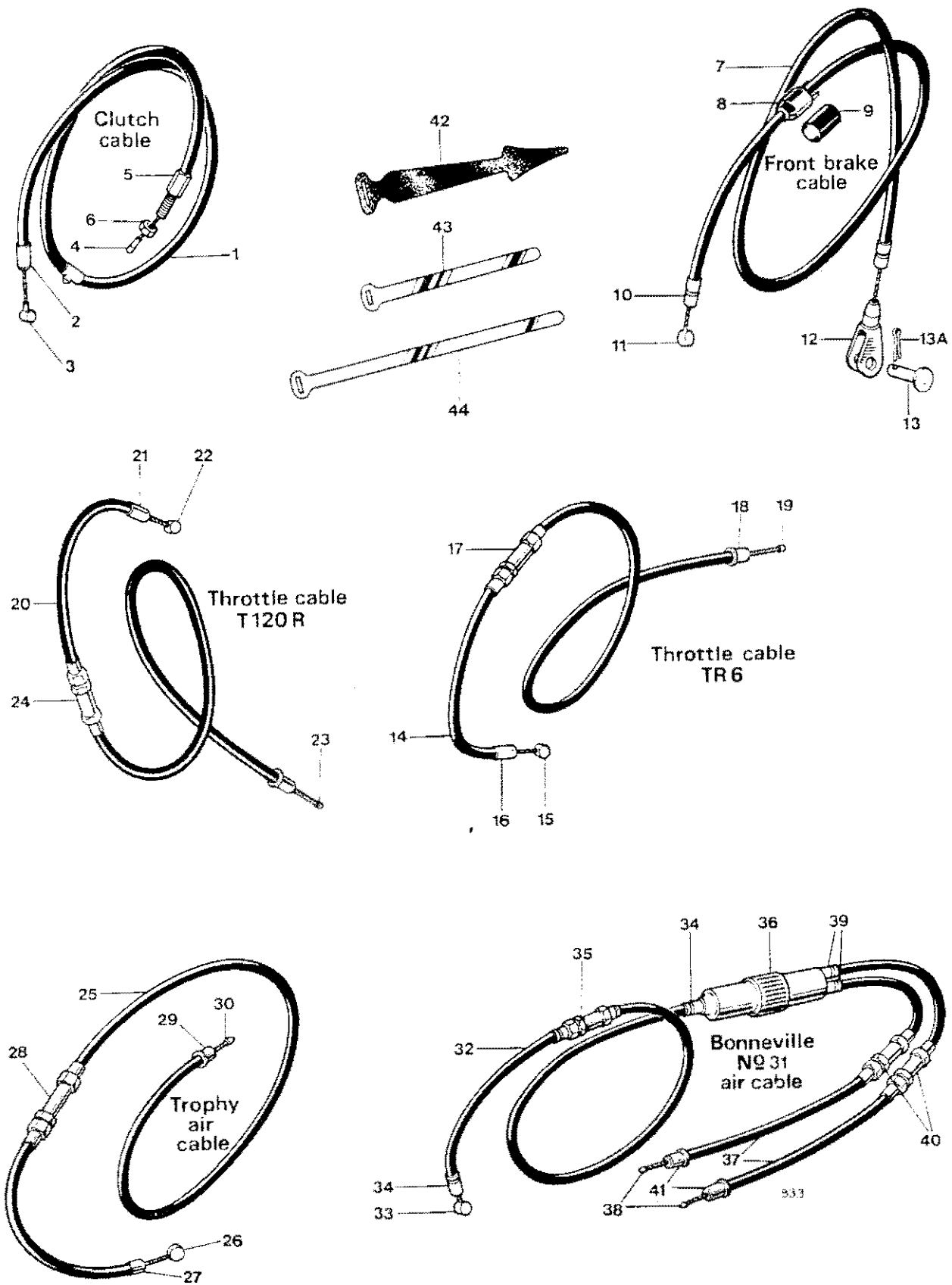

Fig. 27. CONTROL CABLES

Ref. No.	Part No.	DESCRIPTION	QUANTITY	REMARKS
<b>CONTROL CABLES</b>				
1	D1993	CLUTCH CABLE ... ..	1	
2	D103	Ferrule ... ..	2	
3	D506	Nipple (Handlebar end) ... ..	1	
4	DS73	Nipple ... ..	1	
5	D668	Adjuster ... ..	1	
6	S672	Nut ... ..	1	
7	D2076	FRONT BRAKE CABLE (FOR WESTERN BARS)	1	
8	D2085	Front stop switch ... ..	1	
9	D2086	Cover for switch ... ..	1	
10	D103	Ferrule ... ..	2	
11	D506	Nipple (Handlebar end) ... ..	1	
12	D638	Forn end ... ..	1	
13	WF32	Pivot pin ... ..	1	
13A	—	Split pin ( $\frac{1}{16}$ in. x $\frac{3}{8}$ in.) ... ..		Reference only
14	D746	THROTTLE CABLE ... ..	1	TR6
15	D83	Nipple ... ..	1	
16	D101	Ferrule ... ..	3	
17	D104	Adjuster ... ..	1	
18	6/132A	Ferrule ... ..	1	
19	NS191	Nipple ... ..	1	
20	D1819	THROTTLE CABLE ... ..	2	T120
21	D101	Ferrule ... ..	3	each cable
22	D83	Nipple ... ..	1	each cable
23	NS191	Nipple ... ..	1	each cable
24	D104	Adjuster ... ..	1	each cable
25	D747	AIR CONTROL CABLE ... ..	1	TR6
26	D83	Nipple ... ..	1	
27	D101	Ferrule ... ..	3	
28	D104	Adjuster ... ..	1	
29	6/132A	Ferrule ... ..	1	
30	NS191	Nipple ... ..	1	
31	D1817	AIR CONTROL CABLE ... ..	1	T120
32	D1818	CABLE, LEVER TO JUNCTION BOX	1	
33	D83	Nipple ... ..	1	
34	D101	Ferrule ... ..	4	
35	D104	Adjuster ... ..	1	
Not illus.	NS191	Nipple ... ..	1	
36	D685	Junction box (244/104) ... ..	1	
37	D684	CABLE, JUNCTION BOX TO CARBURETOR	2	
38	NS191	Nipple ... ..	2	each cable
39	D101	Ferrule ... ..	3	each cable
40	D104	Adjuster ... ..	1	each cable
41	6/132A	Ferrule ... ..	1	each cable
42	D343/7	Clip, rubber ... ..		as required
43	XA69	Clip, metal ... ..		as required
44	F9918	Clip, metal ... ..	1	

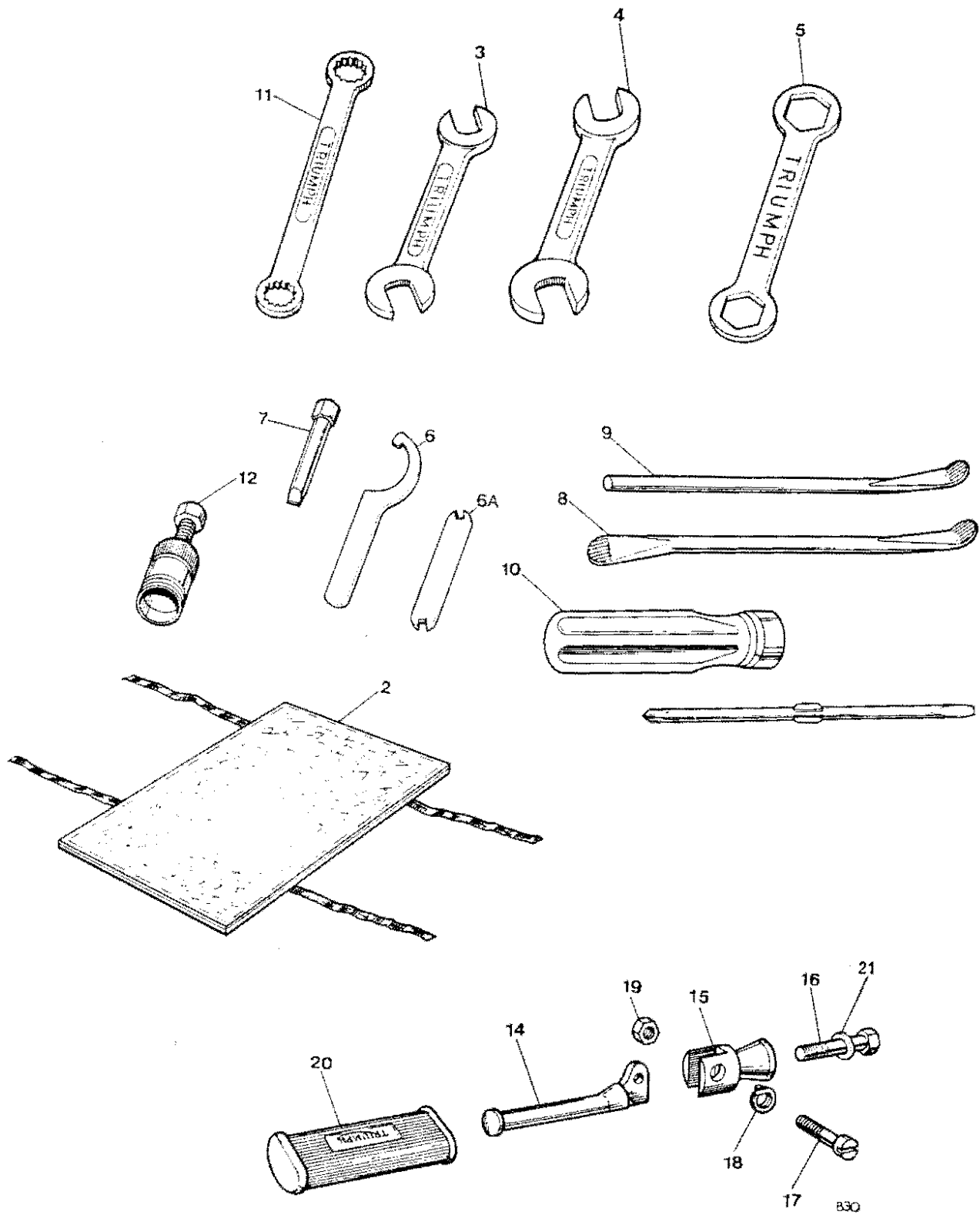

Fig. 28. TOOLKIT AND PILLION FOOTRESTS

**TOOLKIT AND PILLION FOOTRESTS**

1	D2109	TOOLKIT COMPLETE	...	...	...	...	...	...	1	
2	D291	Tool roll	...	...	...	...	...	...	1	
3	D2084	Open spanner $\frac{1}{4} \times \frac{5}{16}$ in. Whit.	...	...	...	...	...	...	1	
4	DA16	Open spanner $\frac{3}{8} \times \frac{7}{16}$ in. Whit.	...	...	...	...	...	...	1	
5	D2251	Ring spanner $1\frac{1}{8} \times 1\frac{5}{16}$ in. A.F.	...	...	...	...	...	...	1	
6	D2184	"C" spanner	...	...	...	...	...	...	1	
6A	D2185	Tappet spanner	...	...	...	...	...	...	1	
7	D2108	Screwdriver for chain tensioner	...	...	...	...	...	...	1	
8	NA14A	Tyre lever	...	...	...	...	...	...	1	
9	D801	Tyre lever and tommy bar	...	...	...	...	...	...	1	
10	D767	Screwdriver	...	...	...	...	...	...	1	
11	D370	Ring spanner $\frac{3}{16} \times \frac{1}{4}$ in. Whit.	...	...	...	...	...	...	1	
12	D1861	Clutch hub extractor	...	...	...	...	...	...	As required	
13	F9369	PILLION FOOTREST	...	...	...	...	...	...	2	
14	F1694	Pedal	...	...	...	...	...	...	2	
15	F9370	Hanger	...	...	...	...	...	...	2	
16	S1910	Bolt ( $\frac{1}{8}$ in. U.H.)	...	...	...	...	...	...	2	
17	F9371	Pivot bolt	...	...	...	...	...	...	2	
18	F2277	Thrackeray (spring) washer	...	...	...	...	...	...	2	
19	14-0302	Nut	...	...	...	...	...	...	2	
20	F1695	Pedal rubber	...	...	...	...	...	...	2	
21	S26-1	Washer	...	...	...	...	...	...	2	

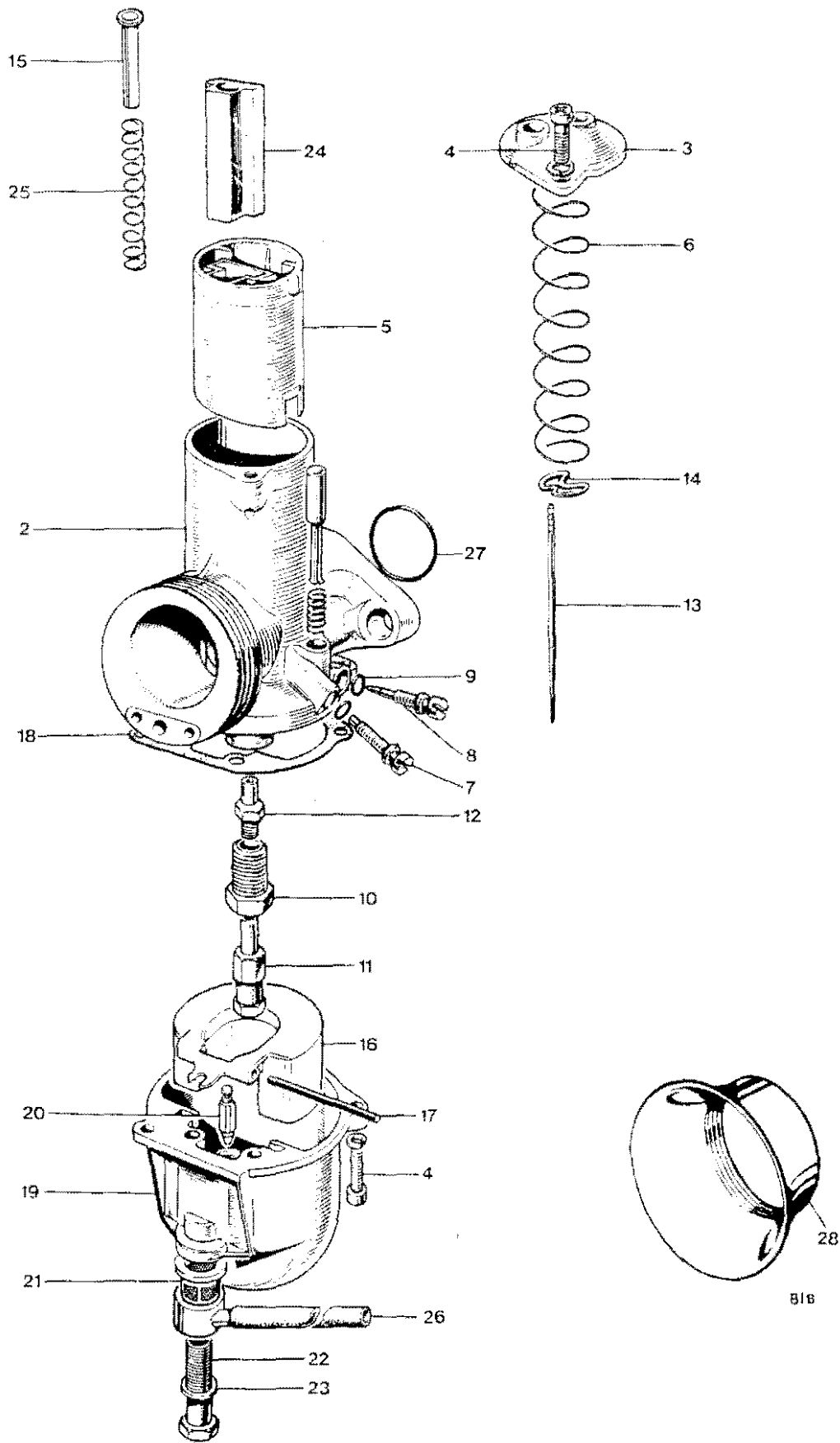

Fig. 29. AMAL CARURETOR, TR6R, TR6C



Ref. No.	Part No.	DESCRIPTION	QUANTITY	REMARKS
<b>AMAL CARBURETOR TR6R, TR6C</b>				
1	D2183	CARBURETOR (R930/23) less "O" ring ...	1	
2	Reference only	Mixing chamber (930/005) ...	1	
3	928/098	Mixing chamber top (99-1032) ...	1	
4	622/086	Screw (99-0521) ...	4	
5	928/060	Throttle valve (3½ cutaway) (99-0527) ...	1	
6	622/131	Throttle return spring (99-1033) ...	1	
7	622/077	Throttle stop screw (99-0516) ...	1	
8	622/076	Air adjusting screw (99-0515) ...	1	
9	622/082	"O" ring (99-0520) ...	2	
10	622/128	Jet holder (99-1034) ...	1	
11	376/100	Main jet (230) (99-0450) ...	1	
12	622/122	Needle jet (0-106) (99-1035) ...	1	
13	622/124	Needle (99-1036) ...	1	
14	622/067	Needle clip (99-0510) ...	1	
15	928/103	Air valve guide sleeve (99-1037) ...	1	
16	622/069	Float (99-0512) ...	1	
17	622/071	Float spindle (99-0513) ...	1	
18	622/073	Joint washer (99-0514) ...	1	
19	622/050	Float chamber (99-0506) ...	1	
20	622/068	Needle (99-0511) ...	1	
21	376/093	Filter (99-0438) ...	1	
22	622/078	Banjo bolt (99-0517) ...	1	
23	376/092	Fibre washer (99-0437) ...	1	
24	928/062	Air slide (99-0528) ...	1	
25	622/129	Spring (99-1038) ...	1	
26	F9271	Petrol pipe ...	1	
27	E9711	"O" ring ...	1	
28	99-0530	Air intake tube ...	Available	

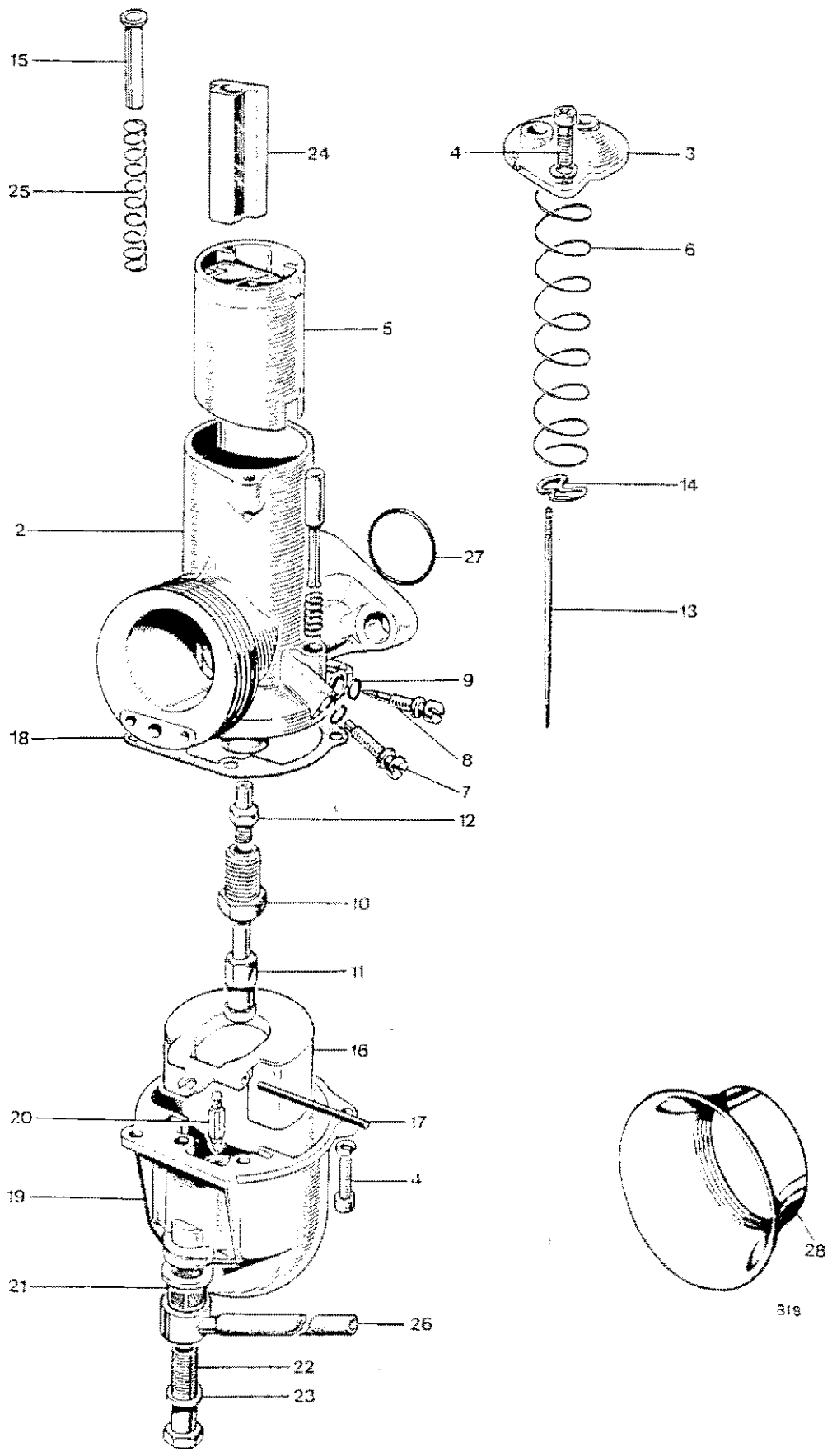

Fig. 30. AMAL CARBURETOR, T120R

Ref. No.	Part No.	DESCRIPTION	QUANTITY	REMARKS
----------	----------	-------------	----------	---------

**AMAL CARBURETOR T120R**

1	D771	CARBURETOR—L.H. (L930/10)	1	} Less "O" ring
1	D772	CARBURETOR—R.H. (R930/9)	1	
2	Reference only	Mixing chamber (L930/005 and R930/005)	1	} Each carburettor
3	928/098	Mixing chamber top (99-1032)	1	
4	622/086	Screw (99-0521)	4	
5	928/060	Throttle valve (3 cutaway) (99-0527)	1	
6	622/131	Throttle return spring (99-1033)	1	
7	622/077	Throttle stop screw (99-0516)	1	
8	622/076	Air adjusting screw (99-0515)	1	
9	622/082	"O" ring (99-0520)	2	
10	622/128	Jet holder (99-1034)	1	
11	376/100	Main jet (99-0446) (190)	1	
12	622/122	Needle jet (99-1035) (0-106)	1	
13	622/124	Needle (99-1036)	1	
14	622/067	Needle clip (99-0510)	1	
15	928/103	Air valve guide sleeve (99-1037)	1	
16	622/069	Float (99-0512)	1	
17	622/071	Float spindle (99-0513)	1	
18	622/073	Joint washer (99-0514)	1	
19	622/050	Float chamber (99-0506)	1	
20	622/068	Needle (99-0511)	1	
21	376/093	Filter (99-0438)	1	
22	622/078	Banjo bolt (99-0517)	1	
23	13/163	Fibre washer (99-0000)	1	
24	928/062	Air slide (99-0528)	1	
25	622/129	Spring (99-1038)	1	
26	F8133	Petrol pipe	1	
27	E9711	"O" ring	2	
28	928/066	Air intake tube (99-0530)	Available	

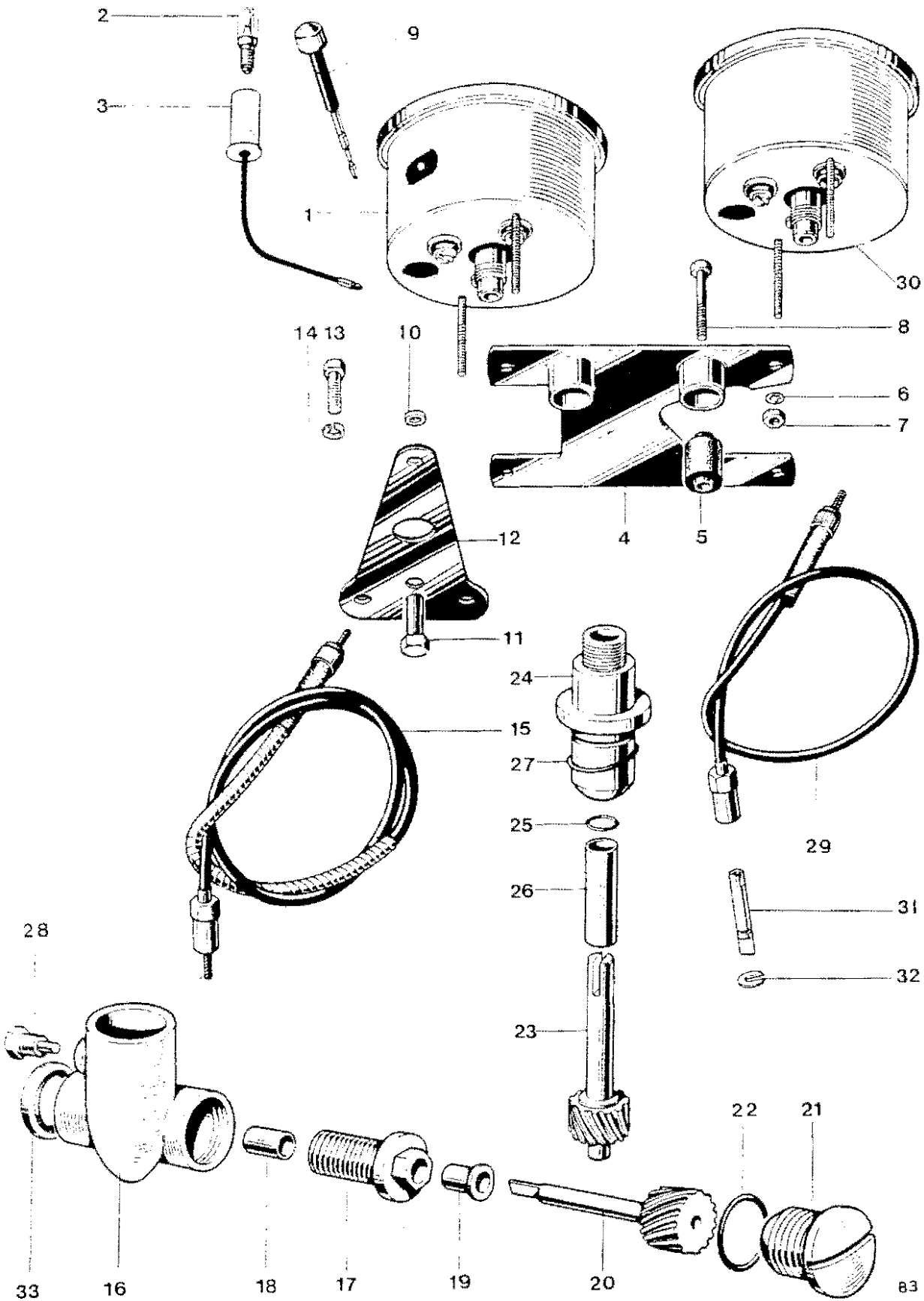

Fig. 31. SPEEDOMETER AND TACHOMETER

Ref. No.	Part No.	DESCRIPTION	QUANTITY	REMARKS
<b>SPEEDOMETER AND TACHOMETER</b>				
1	D1930	Speedometer head MPH (SSM5001/06)	1	
Not illus.	31-315-135	Brass fitting at cable connection	1	
2	643	Bulb 3W-MES	1	
3	554710	Bulb holder (99-0695)	1	
4	H1946	MOUNTING BRACKET	1	} TR6R, T120R
5	H1929	Metalastik bush	2	
6	30-282-01411	Washer	2	
7	30-276-03711	Nut	2	
8	S590	Bolt (1 $\frac{3}{16}$ in. U.H.)	2	
9	41-148-203	Trip control	1	
10	H1702	Distance piece	2	} TR6C
11	H1701	Sleeve nut	2	
12	H2138	Bracket	1	
13	14-0101	Bolt ( $\frac{1}{2}$ in. U.H.)	2	
14	S26-2	Spring washer	2	} Smiths DF9110/00
15	D609	Speedometer cable (65 ins. long) (D609W inner only)	1	
16	E9331	TACHOMETER GEARBOX (E5758 Body) L.H. thread	1	
17	E9332	Securing screw L.H. thread, UN	1	
18	Reference only	Bush	1	
19	Reference only	Flanged bush	1	
20	E5157	Driving gear	1	
21	E5759	End cap	1	
22	E6300	"O" ring	1	
23	E5578	Driven gear	1	
24	E6122	Driven gear housing	1	
25	E6299	"O" ring	1	
26	Reference only	Bush	1	
27	E3309	"O" ring	1	
28	E5881	Sec screw	1	
29	D578	Tachometer cable (28 in. long) (D578W inner only)	1	
30	RSM3003,01	Tachometer (99-0166)	1	
31	31-371-398	Spade	1	
32	D494	Circlip	1	
33	E7351	Sealing washer	1	
Not illus.	D546	Blanking plug (replaces tacho bulb holder)	1	

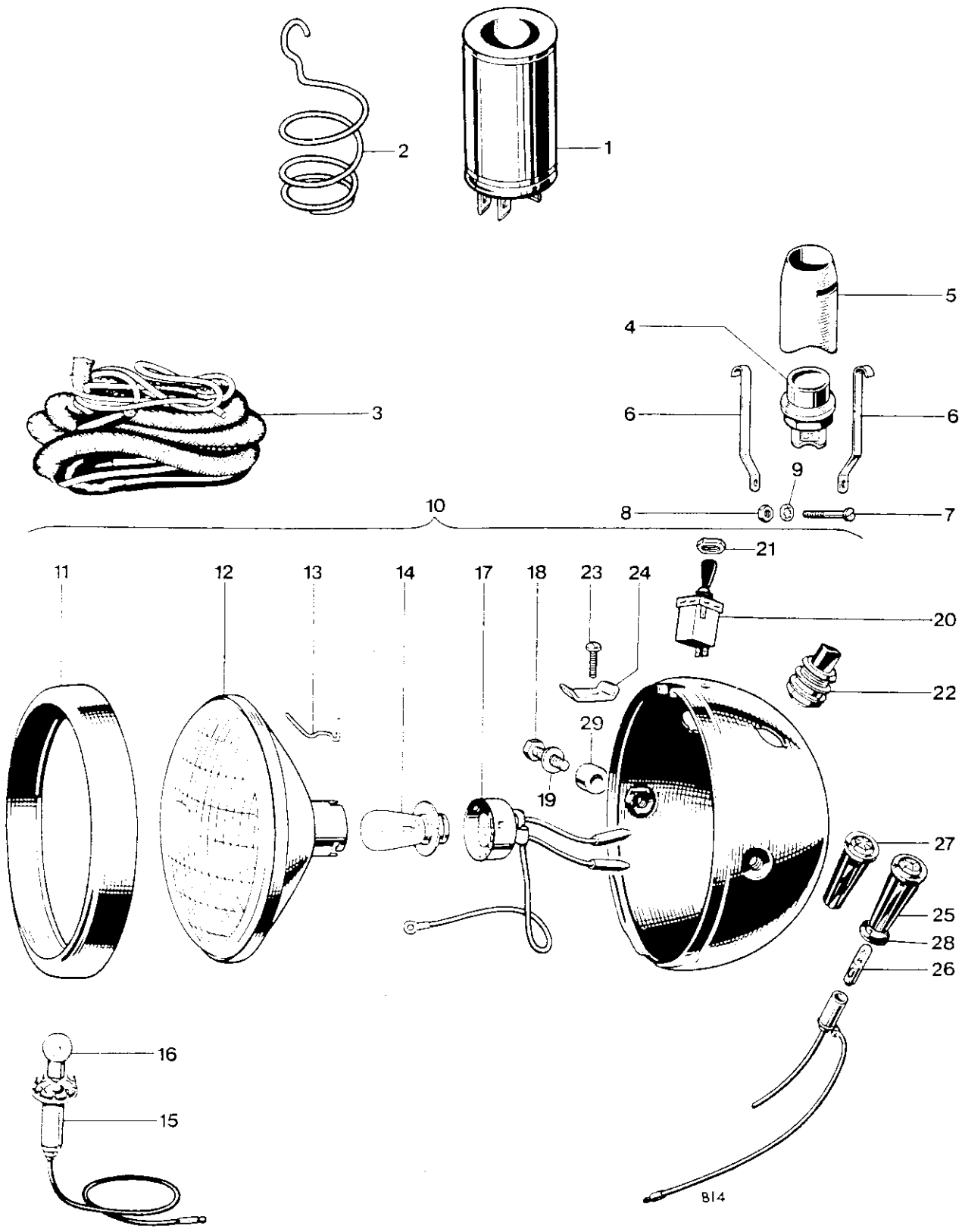

Fig. 32. IGNITION CAPACITOR AND HEADLAMP, TR6C

Ref. No.	Part No.	DESCRIPTION	QUANTITY	REMARKS
----------	----------	-------------	----------	---------

**IGNITION CAPACITOR AND HEADLAMP, TR6C**

1	Type 2MC	Ignition capacitor (99-0737) (54170009)	...	Available
2	54483156	Capacitor mounting spring (99-0778)	...	Available
3	54957096	Wiring harness (99-0000)	...	1
4	35835	Kill button, type 151SA (99-0564)	...	1
5	H2259	Cup	...	1
6	H2034	Clip	...	2
7	H687	Bolt ( $\frac{3}{8}$ in. U.H.)	...	1
8	H745	Nut	...	1
9	GS299	Serrated washer (for H745)	...	1
10	59965	HEADLAMP ASSEMBLY (99-0000)	...	1
11	534343	Rim (99-0691)	...	1
12	54524526	Light unit (99-1041)	...	1
13	504665	Fixing wire (99-0683)	...	6
14	464	Bulb (40/27W, vertical dip, Pre focus 99-1042)	...	1
15	54573590	Bulbholder, pilot (99-0695)	...	1
16	989	Bulb (3W, M.C.C. 99-0548)	...	1
17	554602	Adaptor c/w leads (99-1003)	...	2
18	112201	Bolt, lamp fixing (99-1004)	...	2
19	137498	Washer (99-1005)	...	2
20	35710	Lighting switch (99-0563)	...	1
21	153631	Nut for lighting switch	...	Reference only
23	144921	Screw	...	Reference only
24	534296	Plate (99-0690)	...	1
25	38189	Warning light, red (99-0568)	...	1
26	281	Bulb (2W, BA75) (99-0537)	...	2
27	38191	Warning light, green (99-0569)	...	1
28	54140331	Sealing washer	...	Reference only
29	H2362	Distance piece	...	2

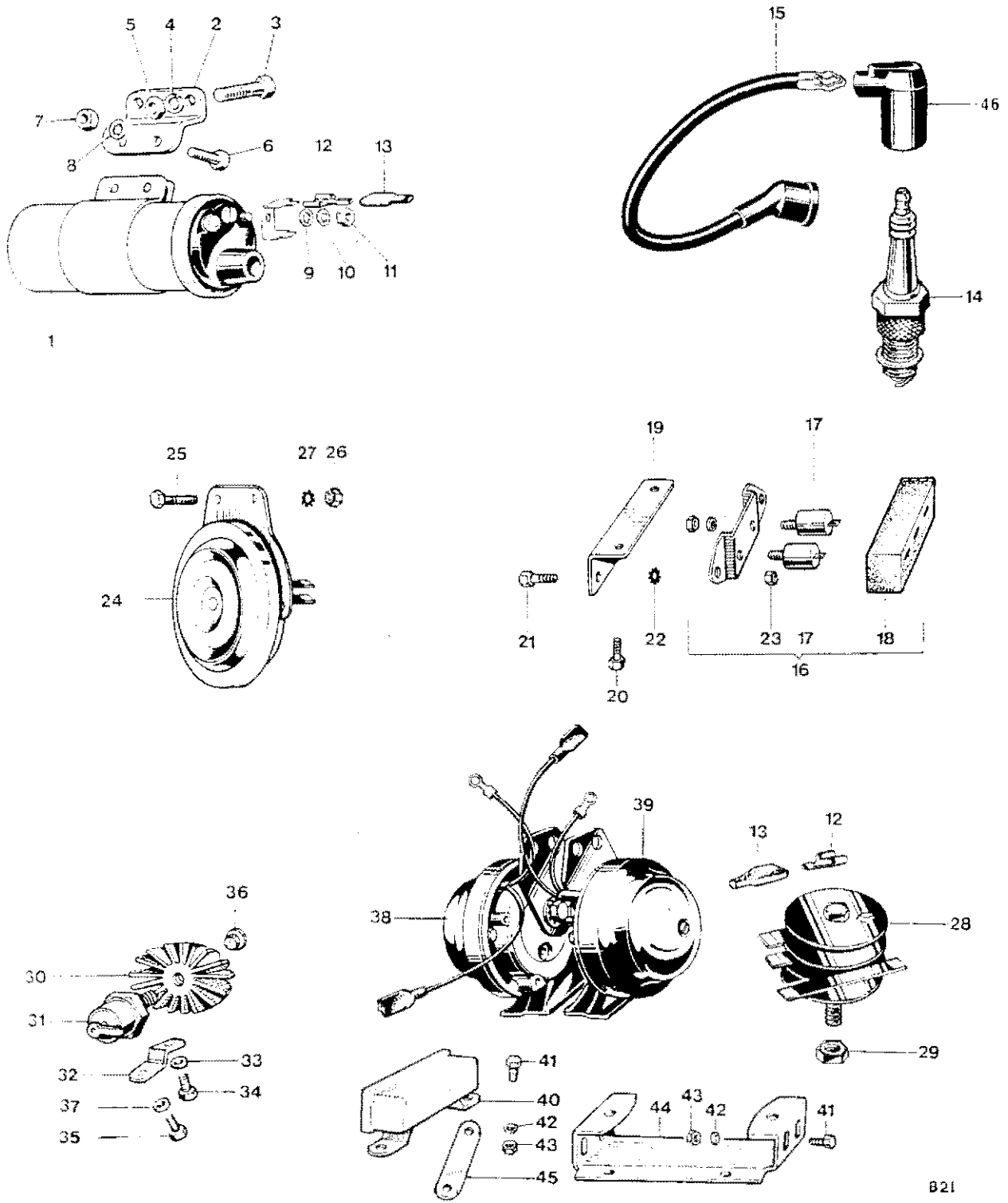

Fig. 33. IGNITION COILS, HORN, RECTIFIER AND ZENER DIODE



Ref. No.	Part No.	DESCRIPTION	QUANTITY	REMARKS
----------	----------	-------------	----------	---------

**IGNITION COILS, HORN, RECTIFIER AND ZENER DIODE**

1	45223	Ignition coil (D2206) Lucas Type 17 M12	1	
2	F11533	Coil bracket	2	
3	14-0215	Bolt (coil to frame bracket)	2	
4	S26-3	Washer	2	
5	14-0302	Nut	2	
6	14-0103	Boil (coil to bracket)	4	
7	14-0301	Nut	4	
8	E1612	Serrated washer	4	
9	131023	Plain washer E2351	4	
10	188330	Serrated washer (GS299)	4	
11	166043	Nut (F3799)	4	
12	54942078	Lucar connector	as required	
13	54190042	Insulating cover	as required	
14	N3	Champion sparking plug	2	
15	D2207	H.T. cable c/w clip and grommet (54956466)	1	
16	47638	CONDENSER PACK 2CP (99-0588)	1	
17	54420128	Condenser (99-1043)	2	
18	54418528	Cover (99-0767)	1	
19	F8082	Condenser pack bracket (54418528)	1	
20	E8287	Boilt, bracket to frame	2	
21	F10033	Boilt, pack to bracket	2	
22	GS299	Shakeproof washer	2	
23	F3799	Nut	2	
24	70183	Horn, type 6H (99-0612)	1	TR6R, TR6C
25	F4771	Screw ( $\frac{3}{8}$ in. U.H.)	2	
26	F3799	Nut	3	
27	G5299	Serrated washer	3	
28	49072	Rectifier, type 2D5 506 (99-0589)	1	
29	F5338	Nut	1	
30	H2237	Heat sink	1	
31	49345	Zener Diode (99-0590)	1	
32	H2365	Bracket	1	
33	S26-2	Washer	1	
34	14-6102	Bolt (bracket to heat sink)	1	
35	14-0113	Bolt (bracket to fork)	1	
36	H2275	Plug heat sink	1	
37	S26-3	Washer	1	
38	D2256	Horn R.H.	1	}
39	D2257	Horn L.H.	1	
40	33188	Horn relay (99-1027)	1	} T120R
41	14-0103	Boilt	6	
42	S26-2	Washer	6	
43	14-0301	Nut	6	
44	F11254	Bracket	1	
45	F7582	Relay stay	1	
46	D262	Plug cap—Champion WC548	2	

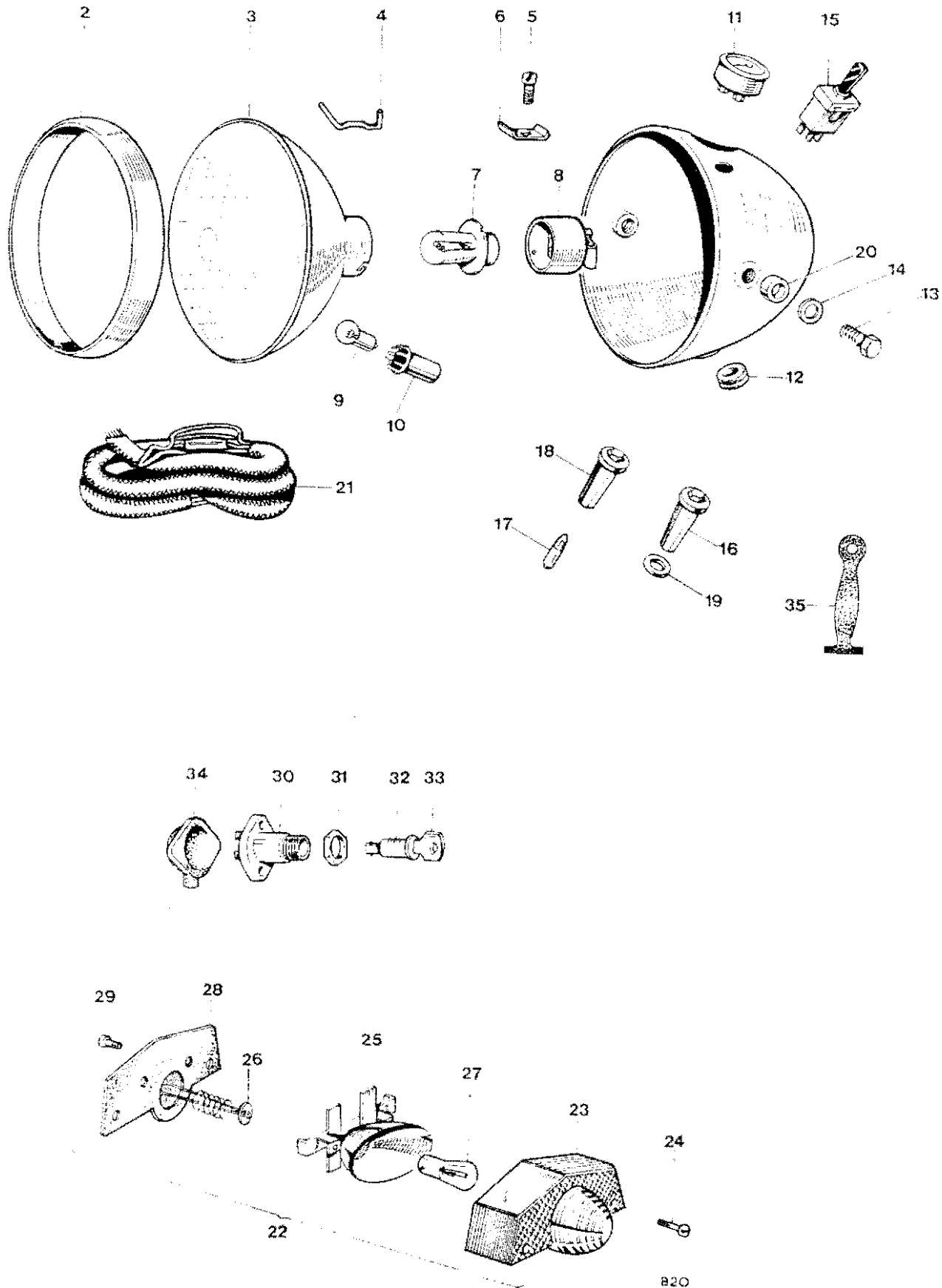

Fig. 34. HEADLAMP, WIRING HARNESS, SWITCHES AND TAIL LAMP

## HEADLAMP, WIRING HARNESS, SWITCHES AND TAIL LAMP

### TR6R, T120R

1	59969	HEADLAMP COMPLETE TYPE SS700P	1	
2	553248	Rim (99-0692)	1	
3	516798	Light unit (99-0686)	1	
4	504665	Fixing wire (99-0683)	6	
5	144921	Screw		Reference only
6	534296	Plate (99-0690)	1	
7	446	Bulb (50/40W vert dip pre focus) (99-0545)	1	
8	554602	Main bulbholder (99-1003)	1	
9	989	Bulb (6W MCC) (99-0548)	1	
10	54573590	Pilot bulbholder (99-0695)	1	
11	36403	Ammeter, type 2AR (99-1044)	1	
12	862217	Grommet		Reference only
13	112201	Bolt (99-1004)	2	
14	137498	Plain washer (99-1005)	2	
15	35710	Lighting switch (99-0563)	1	
16	38189	Warning light body (red) (99-0568)	1	
17	281	Bulb (2W BA7S) (99-0537)	2	
18	38191	Warning light body (green) (99-0569)	1	
19	54140331	Sealing washer		Reference only
20	H1932	Distance piece	2	
21	54957095	Wiring harness (99-0000)	1	
22	53973	Stop and tail lamp, type L679 (99-0597)	1	
23	54577109	Lens (99-1046)	1	
24	144921	Screw		Reference only
25	54574348	Bulb holder with reflector (99-0783)	1	
26	573828	Contact assembly (99-0701)	1	
27	380	Bulb (6/12W offset pin) (99-0542)	1	
28	54571677	Gasket (99-0780)	1	
29	127684	Screw		Reference only
30	31899	Ignition switch, type 545 (99-0558)	1	
31	54130041	Nut (99-1000)	1	
32	F6981	Ignition lock c/w keys	1	
33	D622	Ignition key (state serial No.)		As required
34	H2262	Ignition switch cover	1	
35	D343/3	Cable clip (rear lamp)	1	